

Actuated Translucent Controls for Dynamic Tangible Applications on Interactive Tabletops

Malte Weiss
RWTH Aachen University
weiss@cs.rwth-aachen.de

Florian Schwarz
RWTH Aachen University
florian.schwarz@rwth-aachen.de

Jan Borchers
RWTH Aachen University
borchers@cs.rwth-aachen.de

ABSTRACT

We present a novel type of tangible controls for interactive tabletops: actuated general-purpose widgets that are used to manipulate digital data on interactive tabletops. Due to their transparency the visual appearances can be changed dynamically. Unlike previous approaches, our widgets can be arranged and configured on the tabletop by employing an array of electromagnets beneath the multi-touch surface. This enables a bilateral communication between the user and the multi-touch application while keeping the controls untethered, low-cost, and easy to build.

Author Keywords

Tangible user interface, general-purpose, widgets, actuated tangibles

ACM Classification Keywords

H.5.2 Information Interfaces and Presentation: User Interfaces—*Input Devices and Strategies*

INTRODUCTION

As interactive tables are becoming increasingly relevant for the use in everyday applications, there is a need for general-purpose controls to manipulate arbitrary virtual data. Although direct touch interaction with virtual on-screen controls represents a natural input method, it lacks tactile feedback. This requires the user to look on the virtual control she is interacting with rather than to focus on the data that she manipulates. SLAP Widgets [7] provide transparent, general-purpose tangible user interfaces (TUIs) that can be placed on the tabletop to interact with digital objects. However, as many TUIs these widgets are static. Although, their visual representation can be changed dynamically by exploiting their transparency, the physical objects can only be controlled by the user. If the system changes the state of a widget, e.g., the level of a volume control, this modification is not reflected by the physical widget. This weakens the perceptual coupling of the tangible representations (the physical state of the widgets) to the dynamic intangible representations (the visual rendering of the widget's state) as demanded by [2].

We extend the idea of SLAP Widgets [7] by actuating the controls. This allows the software to react on system events and to arrange and configure the widgets. As in [7], our widgets are transparent, low-cost, and we hide the underlying

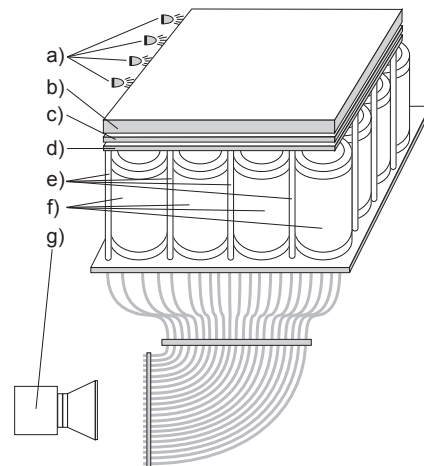

Figure 1. a) IR-LEDs. b) Acrylic layer. c) LCD panel. d) EL foil. e) Fiber optic cables. f) Magnets. g) IR-Camera.

technology, following the spirit of Ubiquitous Computing [6], by making them completely passive.

RELATED WORK

Our work is inspired by the Actuated Workbench [3] which employs an array of electromagnets beneath the table to free-ly position tangible “pucks” on a surface. In [4], Patten and Ishii extend this approach by physical constraints, e.g., in order to ensure a minimum or maximum distance between objects. However, both projects only move pucks on the table and do not provide mechanisms to adjust complex widgets. Furthermore, the authors use a top projection which hampers the dynamic relabeling of the widgets.

Other approaches involve motors to dynamically change the state of a widget, such as the BounceSlider [1], or robotic tangibles [5] that can drive to arbitrary positions on the table. However, the use of electronics, cables, or batteries hinders the applicability on tabletops and complicates dynamic relabeling.

TABLETOP DESIGN

As Figure 1 illustrates, we apply the approach of the Actuated Workbench in our tabletop system. We realize the movement of tangibles by triggering electromagnets that are arranged in an array in the undermost layer. On top a LCD panel is mounted for the output of the visual interface. We intentionally avoid a top projection to maintain the illusion that the visual back-projection is merged with the translu-

cent physical objects. An electroluminescence (EL) foil beneath the LCD surface provides the backlighting. Since we want to detect objects as well, we employ a visual approach: a modified Frustrated Total Internal Reflection (FTIR) technique senses touches and visual markers on the tabletop. Infrared light is radiated from the borders of the tabletop into an acrylic layer. Because the electromagnets are opaque, we use fiber optic cables breaching the EL foil to transmit this IR-light to a camera.

WIDGET SET

Our widget design bases on the SLAP Widgets: they are also made of transparent acrylic and silicone to change their appearance dynamically via back projection (Figure 2a). However, we extend their footprints as illustrated in Figure 2b. Beside the visual markers (white) on the base of each widget for tracking its position and state we add magnetic markers to automatically arrange and configure widgets on the table. Two magnetic markers (red) are used to move and rotate the entire widget knob, whereas a smaller, lightweight magnetic marker (green) in the middle changes the knobs state. Our widget set contains knobs, sliders, keypads, and keyboards. In addition to [7], we add a knob with a physical constraint: the knob blocks at a certain rotation angle which is particularly useful to communicate range limits in a tactile way, e.g., in a volume control.

ACTUATION

According to [4], predictable and smooth tangible movement is a fundamental interaction capability. However, the known magnetic actuation algorithms, such as Manhattan motion [3], are insufficient to align complex widgets or to move parts of it, like the orbiting arm of the knob. Therefore, we use an algorithm that solves the conflicting forces under the condition that every magnetic marker moves to a distinct position. Thus, moving parts of widgets, such as

the knob's orbiting arm, can be translated by actuating the corresponding magnetic markers, while keeping the knob in place by fixing the remaining markers.

APPLICATIONS

Our actuated widgets can transfer many operations known from desktop GUIs to tangible user interfaces on tabletops. These include initial widget alignment at startup, undo and redo (Figure 2c-d), as well as saving, restoring, and cleaning the table after finishing a task. Moreover, mechanisms like snapping, fixing, and grouping a set of tangibles are conceivable. The widgets can also be equipped with vibration feedback and dynamic range limits. Finally, the actuated widgets will be especially useful for remote collaboration on tabletops by synchronizing tangible widgets of distant users.

FUTURE WORK

We are building the tabletop system and implementing the actuating algorithm. We will apply an iterative approach to design and evaluate the user interface and gestures that support the aforementioned applications. Finally, we will conduct user studies to evaluate the usability and acceptance of our system.

ACKNOWLEDGEMENTS

This work was funded in part by the German B-IT Foundation.

REFERENCES

1. R. Gabriel, J. Sandsjö, A. Shahrokni, and M. Fjeld. BounceSlider: actuated sliders for music performance and composition. In *TEI '08*, pages 127–130, New York, NY, USA, 2008. ACM.
2. H. Ishii. Tangible Bits: Beyond Pixels. In *TEI '08*, pages xv–xxv, New York, NY, USA, 2008. ACM.
3. G. Pangaro, D. Maynes-Aminzade, and H. Ishii. The Actuated Workbench: computer-controlled actuation in tabletop tangible interfaces. In *SIGGRAPH '03*, pages 699–699, New York, NY, USA, 2003. ACM.
4. J. Patten and H. Ishii. Mechanical constraints as computational constraints in tabletop tangible interfaces. In *CHI '07*, pages 809–818, New York, NY, USA, 2007. ACM.
5. D. Rosenfeld, M. Zawadzki, J. Sudol, and K. Perlin. Physical objects as bidirectional user interface elements. *IEEE Comput. Graph. Appl.*, 24(1):44–49, 2004.
6. M. Weiser. The computer for the 21st century. *Scientific American*, 265(3):94–104, 1991.
7. M. Weiss, J. Wagner, Y. Jansen, R. Jennings, R. Khoshabeh, J. Hollan, and J. Borchers. SLAP Widgets: bridging the gap between virtual and physical controls on tabletops. *CHI '09*, Apr 2009.

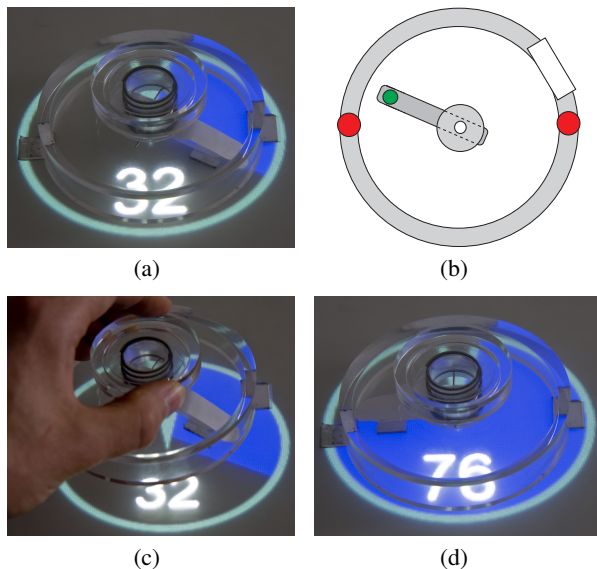

Figure 2. Actuated Knob. a) Rear projection is used to change widget's visual appearance. b) Visual and magnetic footprint. c) Undo is triggered by lifting the knob. d) When knob is released, the orbiting arm and the virtual representation move back to the previous value.