

Redesigning ARPen: Evaluating Different Marker Placements for Mid-Air Pen Interaction

Master's Thesis
submitted to the
Media Computing Group
Prof. Dr. Jan Borchers
Computer Science Department
RWTH Aachen University

by
René Schäfer

Thesis advisor:
Prof. Dr. Jan Borchers

Second examiner:
Prof. Dr. Torsten Kuhlen

Registration date: 05.02.2020
Submission date: 24.06.2020

Eidesstattliche Versicherung

Statutory Declaration in Lieu of an Oath

Schäfer, René

Name, Vorname/Last Name, First Name

344166

Matrikelnummer (freiwillige Angabe)

Matriculation No. (optional)

Ich versichere hiermit an Eides Statt, dass ich die vorliegende ~~Arbeit~~/Bachelorarbeit/
Masterarbeit* mit dem Titel

I hereby declare in lieu of an oath that I have completed the present ~~paper~~/Bachelor thesis/Master thesis* entitled

Redesigning ARPen: Evaluating Different Marker Placements for Mid-Air Pen Interaction

selbstständig und ohne unzulässige fremde Hilfe (insbes. akademisches Ghostwriting) erbracht habe. Ich habe keine anderen als die angegebenen Quellen und Hilfsmittel benutzt. Für den Fall, dass die Arbeit zusätzlich auf einem Datenträger eingereicht wird, erkläre ich, dass die schriftliche und die elektronische Form vollständig übereinstimmen. Die Arbeit hat in gleicher oder ähnlicher Form noch keiner Prüfungsbehörde vorgelegen.

independently and without illegitimate assistance from third parties (such as academic ghostwriters). I have used no other than the specified sources and aids. In case that the thesis is additionally submitted in an electronic format, I declare that the written and electronic versions are fully identical. The thesis has not been submitted to any examination body in this, or similar, form.

Aachen, 24.06.2020

Ort, Datum/City, Date

Unterschrift/Signature

*Nichtzutreffendes bitte streichen

*Please delete as appropriate

Belehrung:

Official Notification:

§ 156 StGB: Falsche Versicherung an Eides Statt

Wer vor einer zur Abnahme einer Versicherung an Eides Statt zuständigen Behörde eine solche Versicherung falsch abgibt oder unter Berufung auf eine solche Versicherung falsch aussagt, wird mit Freiheitsstrafe bis zu drei Jahren oder mit Geldstrafe bestraft.

Para. 156 StGB (German Criminal Code): False Statutory Declarations

Whoever before a public authority competent to administer statutory declarations falsely makes such a declaration or falsely testifies while referring to such a declaration shall be liable to imprisonment not exceeding three years or a fine.

§ 161 StGB: Fahrlässiger Falscheid; fahrlässige falsche Versicherung an Eides Statt

(1) Wenn eine der in den §§ 154 bis 156 bezeichneten Handlungen aus Fahrlässigkeit begangen worden ist, so tritt Freiheitsstrafe bis zu einem Jahr oder Geldstrafe ein.

(2) Strafflosigkeit tritt ein, wenn der Täter die falsche Angabe rechtzeitig berichtet. Die Vorschriften des § 158 Abs. 2 und 3 gelten entsprechend.

Para. 161 StGB (German Criminal Code): False Statutory Declarations Due to Negligence

(1) If a person commits one of the offences listed in sections 154 through 156 negligently the penalty shall be imprisonment not exceeding one year or a fine.

(2) The offender shall be exempt from liability if he or she corrects their false testimony in time. The provisions of section 158 (2) and (3) shall apply accordingly.

Die vorstehende Belehrung habe ich zur Kenntnis genommen:

I have read and understood the above official notification:

Aachen, 24.06.2020

Ort, Datum/City, Date

Unterschrift/Signature

Contents

Abstract	xvii
Überblick	xix
Acknowledgements	xxi
Conventions	xxiii
1 Introduction	1
1.1 Outline	3
2 Related work	5
2.1 Digital Modeling and Sketching	5
2.2 Modeling with Pens using Augmented and Virtual Reality	7
2.3 Pen Ergonomics	11
2.4 Tracking in Augmented and Virtual Reality .	11
2.5 Pen Tracking	12
2.6 Hand Tracking	13

2.7	ARPen	13
3	Redesigning ARPen	15
3.1	Hardware and Electronics	15
3.1.1	RN4871	16
3.1.2	PCB Design	16
3.1.3	Soldering	18
3.1.4	Connection to a Computer	20
3.1.5	Scripting	21
3.1.6	Buttons and Battery	23
3.1.7	Benefits and Limitations	24
3.2	ARPen model	25
3.2.1	Autodesk Fusion 360	25
3.2.2	Rebuilding the ARPen	26
3.2.3	Dimensions	26
3.2.4	Printing	27
3.2.5	ARPen Buttons	28
3.2.6	Benefits and Limitations	29
4	Marker Placement	31
4.1	Positions	31
4.1.1	Back	33
4.1.2	Front	33

4.1.3	Top	33
4.1.4	Combining Placements	34
4.1.5	Combining Different Cube Sizes	34
4.2	Different ARPens	35
4.2.1	Cube Orientation	35
4.2.2	Dimensions	36
4.2.3	Printing and Electronics	36
4.3	Markers	37
4.4	Calculating the Virtual Tip	37
4.4.1	Angles	38
4.4.2	Back and Front	39
4.4.3	Top	42
4.5	Software Adaption	48
5	Study	51
5.1	Aim	51
5.2	Participants	51
5.3	Apparatus	52
5.4	Task	52
5.5	Experimental Design	53
5.6	Study Procedure	53
5.7	Measurements	54

5.7.1	AttrakDiff 2	54
5.7.2	Post-Study System Usability Ques- tionnaire	54
5.8	Results	54
5.8.1	Global Ranking	55
5.8.2	AttrakDiff 2	57
5.8.3	Post-Study System Usability Ques- tionnaire	59
5.8.4	Display	60
5.8.5	Comments	60
	Top	60
	BackTop	61
	TopFront	61
	BackFront	61
	Back	61
	BackFrontSmall	62
	Front	62
5.9	Discussion	62
6	Summary and Future Work	65
6.1	Summary and Contributions	65
6.2	Future Work	66
A	RN4871 code	67

B Study Material	73
B.1 Questionnaire	73
B.1.1 German Questionnaire	74
B.1.2 English Questionnaire	82
B.2 Results	90
 Bibliography	 95
 Index	 101

List of Figures

2.1	Teddy	6
2.2	DodecaPen	8
2.3	Lift-Off Pen	9
2.4	SmartPen	10
2.5	Other Fiducial Markers	12
2.6	ARPen	13
3.1	PCB schematics	17
3.2	Digital PCB layout	17
3.3	Digital layout with component indices	18
3.4	PCB stencil	19
3.5	Adding solder paste to our PCB	19
3.6	The finished PCB	20
3.7	Connection between the adapter and our PCB	21
3.8	Console output after programming the RN4871.	22
3.9	Soldering and arranging the buttons	24

3.10	Autodesk Fusion 360	26
3.11	Comparison of the old and new ARPen	27
3.12	Dimension of our ARPen	28
3.13	Our modified ARPen	28
4.1	Split user focus	32
4.2	Possible cube placements.	32
4.3	ARPen models	35
4.4	ARPen model dimensions	36
4.5	Sketch for the tip calculation	39
4.6	Close Group vs Far Group	42
4.7	Sketch for the tip calculation for the top cube	43
4.8	Triangles for the tip calculation for the top cube	44
4.9	Labeling each side for applying the rotation.	47
4.10	Orientation of ARPen	47
5.1	Study Objects	52
5.2	Ranking of all ARPens	55
5.3	Pragmatic Quality of all ARPens	56
5.4	Evaluational construct for all ARPens.	57
5.5	Post-Study System Usability Questionnaire Results	59
5.6	Display Focus	60

B.1	Post-Study System Usability Questionnaire 1	90
B.2	Post-Study System Usability Questionnaire 2	91
B.3	AttrakDiff 2 Questionnaire 1	92
B.4	AttrakDiff 2 Questionnaire 2	93

List of Tables

3.1	Components of our PCB design.	16
3.2	To program the chip we need to connect the adapter to the PCB as shown here.	21
3.3	Components to connect buttons and a power switch to our PCB.	23
4.1	The Dimensions for each pen in mm. The total length is measured from the front point to the back point. The total height is measured in the same way.	37
4.2	Rotation vectors for the calculation of the pen tip.	47
5.1	Results from Wilcoxon Signed-rank tests with Bonferroni correction for the ranking of all ARPens. Differences between non-listed pairs were not significant with $p > .05$	56
5.2	Pragmatic quality of all ARPens according to the AttrakDiff 2 questionnaire.	57

5.3	Results from Wilcoxon Signed-rank tests with Bonferroni correction for the pragmatic quality of all ARPens according to the AttrakDiff 2 questionnaire. Differences between non-listed pairs were not significant with $p > .05$	58
A.1	Pins and functions of the RN4871 with their internal index.	70
A.2	The messages that are sent when a button changes its state.	71

Abstract

Sketching 3D models in Augmented Reality (AR) enables us to create virtual objects in the place where they are needed. This simplifies the adaption of virtual models in respect to their physical usage without requiring many measurements. Hand-held devices like the ARPen are one possible approach. The ARPen is a 3D printed pen which is used to create 3D models in AR using a smartphone. These models can then be realized using a 3D printer. The smartphone tracks the pen with the help of visual markers which are located on a cube at the back of the pen. In the original version of the ARPen this cube contains most of the hardware, creating an unnatural weight distribution especially for first-time users.

We present a new design of the ARPen. Redesigning the hardware enabled us to relocate the electronics from the cube to the inside of the pen which allowed us to place the cube anywhere on the pen without the need of changing the hardware. Furthermore, the new hardware placement distributes the weight of the electronics more evenly across the pen, leading to a more comfortable grip. This thesis gives detailed information on the redesign of this new ARPen.

We studied the impact different placements of the cube have on subjective user preferences using our new design of the ARPen. The marker placements investigated on the ARPen were on the top, back and front of the pen. Additionally, we investigated the use of two marker cubes. The results from our study show that users preferred using the pen with a top cube.

Überblick

Das Skizzieren von 3D Modellen in Augmented Reality (AR) ermöglicht es uns, virtuelle Objekte dort zu erstellen, wo diese benötigt werden. Dies erleichtert den Prozess, die Modelle, ohne weitere Messungen, an ihren Anwendungsfall anzupassen. In der Hand gehaltene Eingabegeräte, wie der ARPen, sind eine mögliche Technologie für solche Szenarien. Bei dem ARPen handelt es sich um einen 3D-gedruckten Stift, welcher zur Erstellung von 3D Modellen in AR mit Hilfe eines Smartphones verwendet wird. Die so erstellten Objekte können mit einem 3D Drucker gedruckt werden. Das Smartphone nutzt visuelle Marker, welche sich an einem Würfel am Ende des ARPens befinden, um so die Position der Stiftspitze zu berechnen. In der originalen Version des ARPens befindet sich die Hardware größtenteils innerhalb dieses Würfels, was eine unnatürliche Gewichtsverteilung zur Folge hat.

Wir präsentieren ein neues Design des ARPens. Eine Neugestaltung der verwendeten Hardware erlaubt es, diese vollständig aus dem Würfel zu entfernen und in die Stiftbasis zu integrieren. In der Folge kann der Würfel auf dem Stift frei plziert werden, ohne Rücksicht auf die vorhandene Verkabelung nehmen zu müssen. Die Verlegung der Hardware sorgt zudem für eine gleichmäßigere Gewichtsverteilung. Diese Arbeit behandelt die vorgenommene Neugestaltung im Detail.

Wir haben den Effekt auf die subjektive Nutzerwahrnehmung untersucht, welche aus verschiedenen Würfelpositionen resultiert. Die untersuchten Würfelpositionen waren oben, vorne und hinten am Stift, sowie alle Zweierkombinationen aus diesen Positionen. Die Ergebnisse unserer Studie zeigen, dass Nutzer den Stift präferierten, welcher einen Würfel oberhalb der Stiftbasis hat.

Acknowledgements

First of all, I would like to thank Prof. Dr. Borchers and Dr. Kuhlen for examining this thesis.

I would like to thank my supervisors Philipp Wacker and Oliver Nowak. Your input was very helpful and appreciated.

Additionally, I want to thank my family and my friends who supported me throughout this thesis. Especially, I would like to thank Hanja, Franca, Moritz and Fabian for their advice.

Lastly, I want to thank everyone from the Fab Lab for the discussions, and every participant in my study.

Conventions

Throughout this thesis we use the following conventions.

Text conventions

Source code and implementation symbols are written in typewriter-style text.

`myClass`

The whole thesis is written in American English. The first person is written in plural form and unidentified third persons are referred to in male form.

Chapter 1

Introduction

Within the last decades Augmented Reality (AR) and Virtual Reality (VR) have become popular. With Augmented Reality we refer to situations where virtual objects are placed into a mostly real environment. Research in this field went through rapid technological advancements [Azuma et al., 2001, Azuma, 1997] and created great technological diversity [Van Krevelen and Poelman, 2010, Alkhamisi et al., 2013] ranging from head-mounted devices [Thomas and David, 1992] to mobile Augmented Reality [Höllerer and Feiner, 2004], which can nowadays be used by many smartphones. With smartphones becoming more powerful, mobile AR increases its viability.

The ability to place virtual objects in a real environment makes AR usable for in-situ visualizations. Showing the former appearance of cultural buildings is one possible field of application for such in-situ visualizations [Stricker et al., 2010]. A lot of research has been done regarding sketching and modeling 3D objects, as shown in Chapter 2.1 “Digital Modeling and Sketching”. Especially in-situ modeling is very applicable for mobile AR, as it allows designing models and objects right in the place where they are needed. There is evidence that people’s skills for immersive sketching improve rapidly over time [Wiese et al., 2010]. To create in-situ visualizations, sketching and modeling 3D objects in AR is required. These technologies often use pens or pen-like input devices, as drawing with pens is familiar

In-situ modeling allows creating 3D models in the place where they are needed.

Pen input is often used for 3D sketching in AR.

Markers can be used to track moving objects in AR.

The ARPen has all of the used hardware in the cube at the back of the pen, creating an overweight. Additionally, the user splits his focus between the tip of the pen and the marker cube.

to most people. Pen input in combination with appropriate tracking systems, like using VICON cameras [Arora et al., 2018, Wacker et al., 2018], a webcam [Milosevic et al., 2016], or even just one smartphone [Wacker et al., 2019, Seidinger and Grubert, 2016] is feasible for creating 3D content and can be used as a powerful tool. To use these pens, a precise tracking is desirable. Tracking algorithms for AR have improved and are usable for smartphones nowadays. An example for this is the pose tracking of natural features [Wagner et al., 2008]. Markers can be used to support environmental tracking or to track moving objects in AR [Wacker et al., 2019, Yue et al., 2017, Wu et al., 2017, Seidinger and Grubert, 2016].

The ARPen is a bi-manual 3D printed pen-like input device for 3D content creation using mobile AR. It was introduced by Wacker et al. [2019] and will be the focus of this thesis. In Chapter 2.7 “ARPen” we go into more detail about this pen. Currently the ARPen has two major problems. The first problem is that most of its hardware is contained in the cube at the back of the pen, which creates an unnatural weight distribution. The second problem is that the user has to split his focus while using the ARPen. The user wants to look at the tip of the pen (on the display or on the physical pen), as this is the location where drawing actions take place. But at the same time, the marker cube must not leave the camera view, as this would cause the tracking to stop. Since the ARPen is used with one smartphone, and therefore only with one camera, this is a challenge which the user has to overcome. In the current version of the ARPen, these two points of interaction (the tip and the cube) are at the opposite ends of it. The user has to look mainly at the display, which increases the difficulty of drawing on real objects, because of the dual-view problem [Čopić Pucihar et al., 2013, Kruijff et al., 2010]. Other systems [Wu et al., 2017] use a fixed camera position or multiple cameras [Jackson and Keefe, 2016]. These use-cases do not match the idea behind the ARPen.

Using markers to track pens in AR and VR is not new. Systems with pen-like input devices use different marker types and marker placements to meet their goals. The MarkerPen [Seidinger and Grubert, 2016], for example, has a large cube placed near the tip of the pen. This decreases the distance between the tip of the pen and the markers. Since this cube completely surrounds the pen, the user has to hold the pen at its very back and therefore use an unnatural grip. In contrast to this, the pen used in Lift-Off [Jackson and Keefe, 2016] contains five visual markers and combines markers at the back of the pen with a marker at the tip which increases the visibility for the cameras. The DodecaPen [Wu et al., 2017] also has a marker cube at the back of the pen. Since the DodecaPen is a passive stylus, it is thinner than the pen used in Lift-Off and the ARPen. Both the DodecaPen and the ARPen cannot handle occlusion of the markers, as they rely on a single camera.

The MarkerPen has its marker cube close to the tip.

The pen used in Lift-Off contains markers on both ends of the pen.

The DodecaPen has its markers on a cube at the end of the pen.

In this thesis we investigate different marker positions for the ARPen to overcome the problem that the user has to split his focus when using this device. To solve the unnatural weight distribution problem, we look at other pen-like input devices that spread most of the hardware over the whole pen. We redesign the hardware of the ARPen, to move the electronics from the cube to the pen itself. The pen used by Jackson and Keefe [2016], shown in Figure 2.3, is closest to our solution.

1.1 Outline

In the following chapters of this work we will discuss related work, the creation of new hardware for the ARPen, new designs of the ARPen and a study investigating the effects of different marker placements on subjective user preference.

We discuss related work in Chapter 2 “Related work”. Our focus will be on sketching technologies, especially pen-like input devices for Augmented Reality and Virtual Reality.

In Chapter 3 “Redesigning ARPen” we describe our redesign of the ARPen, including improvements on the hardware and the model. We change the hardware in a way such that it can be placed inside the pen rather than inside the cube. This removes weight from the back of the pen and distributes it more evenly over the whole device.

Chapter 4 “Marker Placement” introduces six additional designs of the ARPen. Each pen is different in its placement of the cube containing the markers used to track the pen. Furthermore, we explain the adjustment to the algorithms needed to calculate the position of the tip of the pen for each marker cube and how to integrate the new pens into the corresponding app.

We conducted a study, which we describe and evaluate in Chapter 5 “Study”. The study investigates how the different marker placements compare to each other regarding subjective user ratings.

Finally, we outline future research planned for further enhancing the ARPen in Chapter 6 “Summary and Future Work”.

Chapter 2

Related work

In the following Chapter we introduce related work on digital modeling and sketching. We show various systems that use pen-like input device for modeling and sketching in AR and VR. Afterwards, we give a small introduction on tracking technologies in these fields.

2.1 Digital Modeling and Sketching

The pen is a common (input) device for sketching. A comparison between the mouse and the pen being used as input devices for drawing was done by Apte and Kimura [1993]. According to the authors the participants in their study were approximately twice as fast drawing with the pen than drawing with the mouse and found the pen being more natural to draw with.

Drawing with a pen is faster and more natural than drawing with a mouse.

One of the best known sketching programs is the *Sketchpad*. It was introduced by Sutherland [1964] and was the first interactive computer graphics program. Functions included creating shapes, adding constraints and direct object manipulation. A *light pen* was used with this program. This pen allowed the user to work with the screen comparable to modern touchscreens.

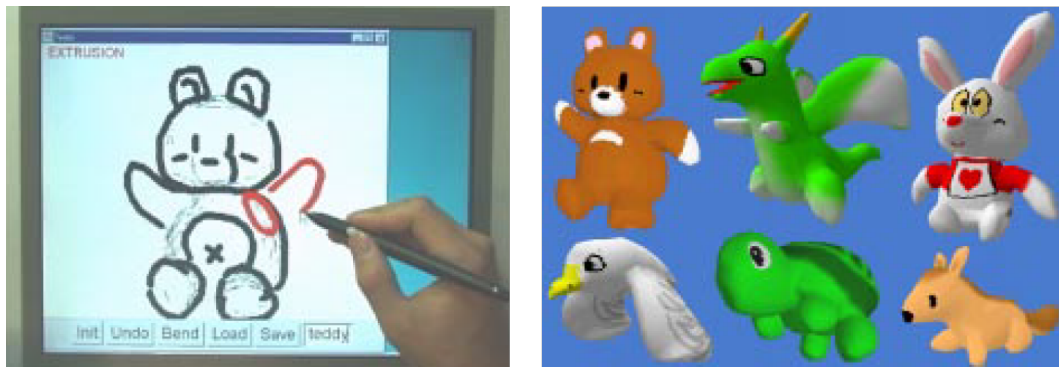

Figure 2.1: The system Teddy (left) is used to create 2D freeform structures and inflates them into plausible 3D objects (right). Images taken from [Igarashi et al., 2006].

Teddy inflates 2D freeform structures into plausible 3D objects.

Teddy by Igarashi et al. [2006] is a system which is easy to learn and enables the user to create 2D freeform structures that are then inflated to 3D. Teddy supports various modeling operations like extruding or cutting. Figure 2.1 shows objects created with Teddy. Like Teddy, Bergig et al. [2009] introduced a system which creates 3D shapes out of 2D sketches. Their system uses a PC, a webcam, a pencil and a sheet of paper instead of drawing on a screen, like Teddy.

In contrast to the previous systems, *Napkin Sketch* is a sketching tool for handheld mixed reality by Xin et al. [2008]. A tablet PC is used to create 3D sketches, which are projected onto a physical piece of paper. The user creates frames where sketches can be projected on.

I Love Sketch enables the user to create 3D drawings from a 2D display.

I Love Sketch is a 3D curve-sketching system by Bae et al. [2008]. The user creates 3D sketches by using a 2D display. The interface allows rotating, zooming and panning. The sketched curves are approximated by Bézier curves and can be interconnected easily. Creating symmetrical shapes by mirroring the sketch is also possible.

The combination of augmented and virtual reality with sketching and 3D modeling has created opportunities to introduce in-situ modeling, meaning to create the models right in the place where they should be. An example is modeling a piece to repair a broken cup. The broken part can be modeled directly in the location where it will be applied. Using AR, it can be projected into the correct spot, simplifying the modeling process.

Combining augmented reality and 3D sketching allows in-situ modeling.

Window-Shaping by Huo and Ramani [2017] enables the in-situ creation of 3D models. In contrast to systems like Napkin Sketch, it does not require specific markers, but works with handheld augmented reality as well. The drawings of the user are mapped according to a point cloud calculated by the device. The sketches can be inflated and manipulated by the user.

Mapping sketches to a 3D curve via a point cloud.

Like *Window-Shaping*, Langlotz et al. [2012] presented a mobile augmented reality system for smartphones, which can be used for 3D content creation. Additionally, it supports content authoring. Tracking within this system is split into two scenes, *outdoor (large)* and *indoor (small)*. Tracking in larger areas is done with panorama-based tracking, while a natural-feature approach is used for smaller areas.

2.2 Modeling with Pens using Augmented and Virtual Reality

Sketching in 3D and in-situ modeling create new opportunities for users. Since pens are a natural drawing tools for humans, the interest in using pens to create models in augmented reality has increased. Therefore, we present an overview of pen-based systems that are used to create or adapt models in 3D. These systems include passive pens, like the *DodecaPen* [Wu et al., 2017], and active pens, like the *ARPen* [Wacker et al., 2019].

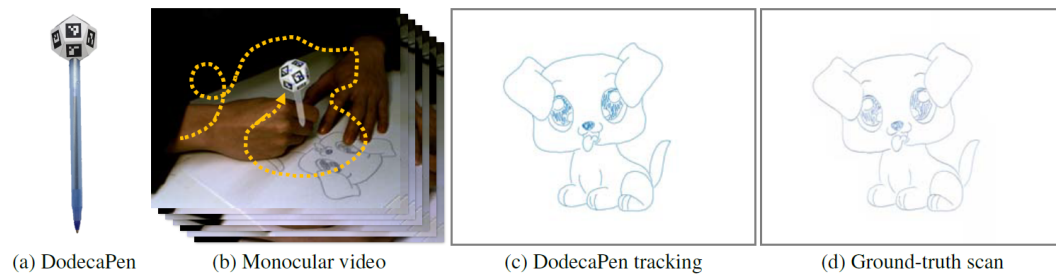

Figure 2.2: The DodecaPen (a) has twelve fiducial markers and allows precise tracking (c and d) using one camera (b). Image taken from [Wu et al., 2017].

Seidinger and Grubert [2016] combine tracking markers with mode selection.

Seidinger and Grubert [2016] introduced the *MarkerPen*, a passive pen which can be used for 3D character customization using a smartphone. The frame markers, which are located on a cube close to the tip of the pen, are used to track the pen and to select the current customization mode.

The DodecaPen offers accurate tracking with 6DoF using fiducial markers and only one camera.

The *DodecaPen* by Wu et al. [2017] is a passive stylus which offers 6DoF (Degrees of Freedom) for drawing. Like the *MarkerPen*, it uses markers for the tracking. In contrast to the four markers of the *MarkerPen*, the *DodecaPen* has twelve fiducial markers at its back and achieves a precision of 0.4mm according to the authors. Figure 2.2 shows the *DodecaPen* and an image that has been created with it. The *DodecaPen* only needs one camera for the tracking process.

SymbiosisSketch by Arora et al. [2018] combines 3D and 2D sketching using curved canvases.

SymbiosisSketch by Arora et al. [2018] enables the user to perform in-situ modeling in 3D by combining 2D and 3D interactions. It contains a motion-tracked pen and a HoloLens. With a few strokes in mid-air, the user can create curved surfaces, which are projected onto a tablet. This way, the user can sketch while having a planar view of the surface. The sketch is constrained to the curved surface created by the user. With this technique, a high precision can be accomplished for modeling and creating details in 3D.

Lift-Off combines 2D reference sketches with an immersive 3D modeling interface.

Lift-Off is an immersive 3D modeling interface which was introduced by Jackson and Keefe [2016]. Like *I Love Sketch*, it combines 2D sketches with 3D modeling, as the user can import 2D sketches. These sketches serve as a reference and help the user to create the desired model. In contrast to *I Love Sketch*, *Lift-Off* does not use a display, but it

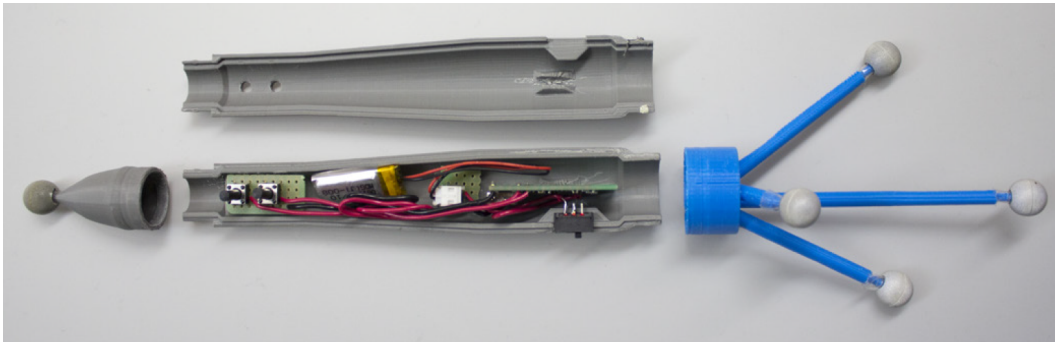

Figure 2.3: The Pen used in Lift-Off contains electronics including two buttons, a switch and a battery. The five visual markers on the back and the front are used for tracking. Image taken from [Jackson and Keefe, 2016].

uses a virtual environment. While SymbiosisSketch enables the user to define planes within the 3D space and add details to them via a tablet, Lift-Off allows importing sketches and using them as a reference to lift-off strokes from those sketches. The modeling in Lift-Off is accomplished using two tracked pens, which are shown in Figure 2.3. 3D modeling using reference images is a technique that is also often used when creating 3D models in programs like [Blender](#)¹.

FreeDrawer was introduced by Wesche and Seidel [2001]. This sketching system is based on a responsive workbench in addition to a head-mounted display. It is capable of drawing and deforming curve networks. Like in Lift-Off, the user is capable of working with both hands simultaneously. One hand performs translations and rotations of the model, while the other hand selects editing tools. A tracked stylus is integrated into *FreeDrawer*.

FreeDrawer can be used to create and deform curve networks.

The *SmartPen* is a pen-shaped device that was introduced by Milosevic et al. [2016]. It has a bendable extended tip. The system consists of a host PC, a webcam and the *SmartPen*. The *SmartPen* has four built-in LEDs, which help the system to estimate its orientation when tracking. According to the authors the system has a tracking accuracy of 1mm within a distance of 1m regarding tracking the pen. Figure 2.4 shows the *SmartPen*.

The *SmartPen* has a bendable tip. Four LEDs help estimating the orientation of the device.

¹<https://www.blender.org/> (Accessed: 15.02.2020)

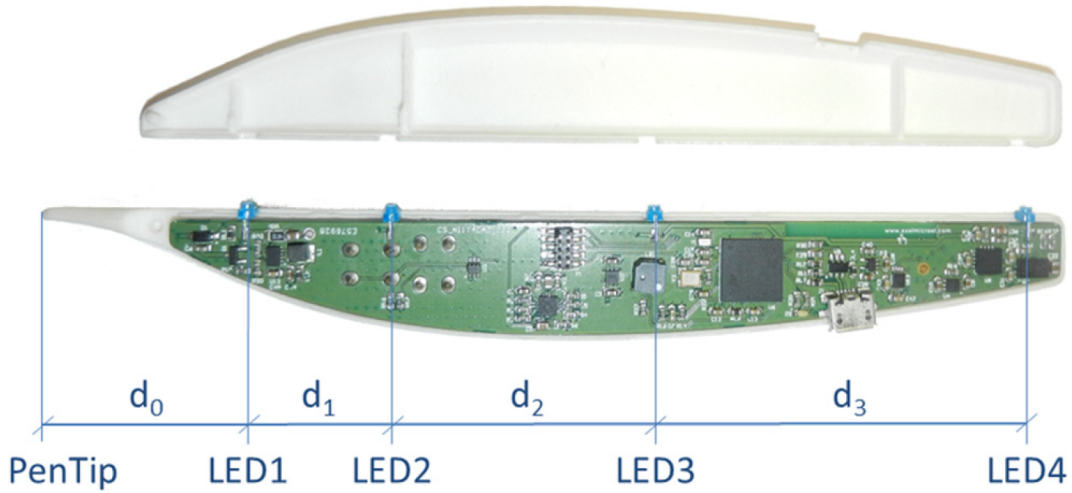

Figure 2.4: The SmartPen has a total length of 159.5mm. The four LEDs are used to estimate the orientation of the device. Image taken from [Milosevic et al., 2016].

The ARPen allows mid-air sketching using a smartphone.

The *ARPen* is a 3D printed pen which is used in combination with a smartphone to allow the user to sketch mid-air. It was introduced by Wacker et al. [2019] and combines the use of fiducial markers, like the DodecaPen does, with the technology of an active stylus, like the devices used in Lift-Off. We further address the ARPen in Chapter 2.7 “ARPen”.

WireDraw supports creating wire frame sculptures by providing guidance regarding the stroke order.

In contrast to creating virtual 3D models, some systems enable the user to create real objects in-situ. For those models, the stroke order is very important, as collisions might occur. Yue et al. [2017] introduced *WireDraw*, a system for the creation of wire frame sculptures. WireDraw uses an Oculus Rift and two web cameras. Their system optimizes the stroke order, so that the wire frame sculpture does not fall apart while drawing. A 3D extruder pen is used to create real sculptures with WireDraw. The virtual wire and an indicator on the pen marker change their color when the pen tip touches the next wire. The pen is tracked using a marker which is placed close to the extruder of the pen.

2.3 Pen Ergonomics

The effect of pen shank sizes was investigated by Goonetilleke et al. [2009]. The participants of their study tested different pens by drawing paths within mazes of three different sizes. Smaller pens (8mm diameter) were more accurate during drawing than larger pens, but tend to be slower. The hexagonal-shaped pen had the worst accuracy. The participants tended to prefer larger pens over the smaller ones, despite their lower accuracy. Regarding the shank shape, the subjective comfort of writing was higher for pens with a circular, or close to circular shank shape. Li et al. [2020] found that a tripod grip at the rear end of a pen allows the largest range of motion in comparison to other grips in VR. For heavier pens, like the input devices used in Lift-Off and the ARPen, this grip may not be feasible.

Participants preferred larger pens despite their lower accuracy in comparison to smaller pens.

2.4 Tracking in Augmented and Virtual Reality

Tracking in augmented and virtual reality is essential, especially when creating 3D models, as the user is required to perform precise movements and designs. There are many different possible solutions on tracking pens and shapes in augmented and virtual reality. The systems covered in Chapters 2.1 “Digital Modeling and Sketching” and 2.2 “Modeling with Pens using Augmented and Virtual Reality” use different technologies and methods to accomplish tracking. Some systems use fiducial markers, like *ArUco*², or *RUNE-Tag* [Bergamasco et al., 2011]. Other systems recognize drawn symbols as markers [Hagbi et al., 2010b]. Teaching new shapes to a system and assigning virtual content to them was investigated by Hagbi et al. [2010a]. Other markers are shown in Figure 2.5. Markers can be used, e.g., to create orientation points for aligning virtual content or for tracking pens, as we will show in the following section.

Markers are used for tracking and placing object in AR and VR.

²<https://sourceforge.net/projects/aruco/> (Accessed: 16.02.2020)

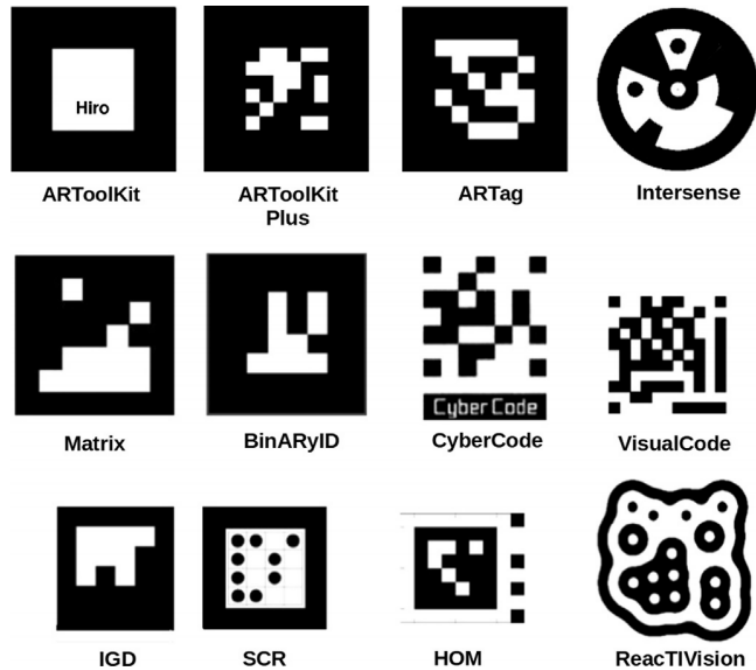

Figure 2.5: Other fiducial markers. Image taken from [Garrido-Jurado et al., 2014].

2.5 Pen Tracking

Pen tracking is often accomplished by attaching visual markers to the pen itself.

Depending on the usage of the system, a different complexity for the tracking is feasible. The *ARPen* [Wacker et al., 2019] and *WireDraw* [Yue et al., 2017] use fiducial markers on the pen. Such markers are also used for the *DodecaPen* [Wu et al., 2017], while frame markers are used on the *MarkerPen* [Seidinger and Grubert, 2016]. Other systems use VICON cameras and visual markers in a fixed setting [Arora et al., 2018, Wacker et al., 2018] or similar systems [Jackson and Keefe, 2016]. Tracking via the use of magnetic fields with smartphones has been done by Yoon et al. [2016]. Some systems also use tracking via infrared [Brandl et al., 2007, Yucel et al., 2010].

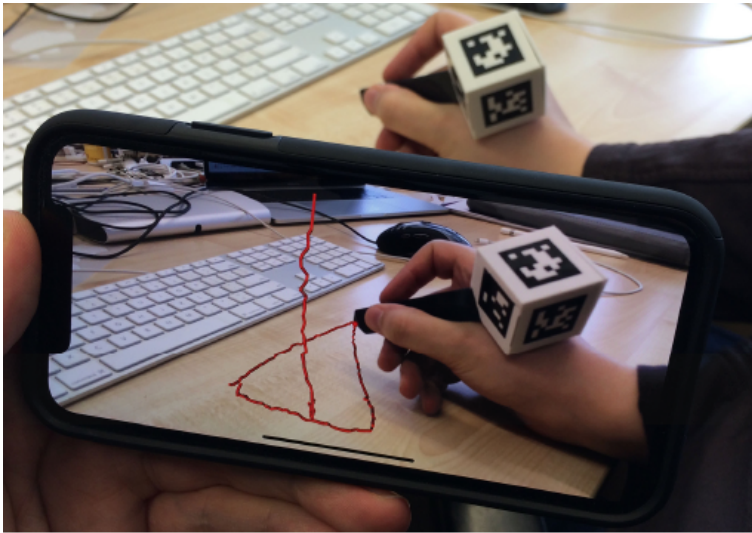

Figure 2.6: The ARPEN allows mid-air sketching. Image taken from [Wacker et al., 2019].

2.6 Hand Tracking

Instead of using visual markers, hands can also be tracked directly. Tracking hands is interesting, as it may provide the systems with more accurate information on the desired position. In these systems, the hands serve as markers and can perform pre-defined gestures [Bai et al., 2014, Wang et al., 2011]. While Bai et al. [2014] focused on handheld augmented reality, Wang et al. [2011] focused on free hand movement with 6DoF using both hands. Fingertip tracking was implemented in *Handy AR* by Lee and Hollerer [2007].

2.7 ARPEN

One of the pen-like input devices for sketching in AR is the ARPEN which was introduced by Wacker et al. [2019]. It consists of a 3D printed pen, a 3D printed marker cube, three buttons, a battery and a *Bluetooth Low Energy* (BLE) module. Together with the corresponding [app](https://github.com/i10/ARPen)³, the ARPEN enables

³<https://github.com/i10/ARPen> (Accessed: 10.02.2020)

the user to sketch mid-air (see Figure 2.6). In contrast to pens like the DodecaPen, the ARPen is an active stylus. If the user presses a button, the BLE module communicates with the app which then processes the signal input. Most of the hardware is located inside the marker cube. This cube is also used by the smartphone to track the position of the pen. Due to the use of a smartphone instead of a more complex setup (e.g. using multiple cameras), the ARPen system is very mobile in comparison to other systems.

Chapter 3

Redesigning ARPen

In this chapter we describe the redesigning process of the ARPen and show how we improve the ARPen regarding electronics, weight distribution and design. In Chapter 3.1 “Hardware and Electronics” we explain the changes of the electronics of the ARPen. We replace the current *Bluetooth Low Energy* (BLE) module with a custom *Printed Circuit Board* (PCB) which is used to implement our new module and can be connected to the electronics inside the ARPen. Chapter 3.2 “ARPen model” deals with the changes we made to the 3D model for the ARPen and how to prepare the printed ARPen for the integration of the electronics.

3.1 Hardware and Electronics

The original version of the ARPen was built using the *Red-Bear BLE Nano V2*. As this chip is neither sold nor produced anymore, we build our new ARPen around the [RN4871](#)¹. Furthermore, we minimize our new hardware to fit inside the pen. This separates the marker cube from the electronics and distributes the electronics more evenly across the whole pen. In this section we explain our PCB design, the soldering of the PCB and the programming of the RN4871.

We use the RN4871 for our new ARPen and create a custom PCB to use it.

¹<http://ww1.microchip.com/downloads/en/DeviceDoc/50002489C.pdf> (Accessed: 20.02.2020)

3.1.1 RN4871

The RN4871 comes with an own scripting language.

The RN4871 is the BLE module we use for our new design of the ARPen. We chose it because it is small enough to fit inside the pen and has a small ASCII scripting language embedded. With this setup, there is no need for an additional microcontroller. Therefore, we also save space on our PCB. We use the RN4871 to monitor the states of all buttons on the ARPen. If the state of a button changes, the RN4871 will notify the connected device about the change. In our case, this device is a smartphone using the corresponding ARPen app.

3.1.2 PCB Design

We use KiCad to create our PCB.

To connect the buttons of the ARPen to the RN4871 we create a custom PCB, which uses the components listed in Table 3.1. The schematics and the digital PCB are displayed in Figure 3.1 and 3.2. We design the PCB with the help of [KiCad²](https://www.kicad-pcb.org/), as it is easy to use and provides all the functionality we need to create our PCB. Figure 3.3 highlights each component listed in Table 3.1.

Index	Component	Quantity
1	RN4871	1
2	Red LED - 1206	1
3	10 μ F Capacitor - 1206	2
4	10nF Capacitor - 603	1
5	4.700 Ω Resistor - 603	1
6	330 Ω Resistor - 603	1
7	LD3985M33R 3V3 Voltage Regulator	1
8	2x3 Right Angle Pin Header 2.54mm	1
9	Legs from Through Hole Resistors	few

Table 3.1: Components of our PCB design.

²<https://www.kicad-pcb.org/> (Accessed: 20.02.2020)

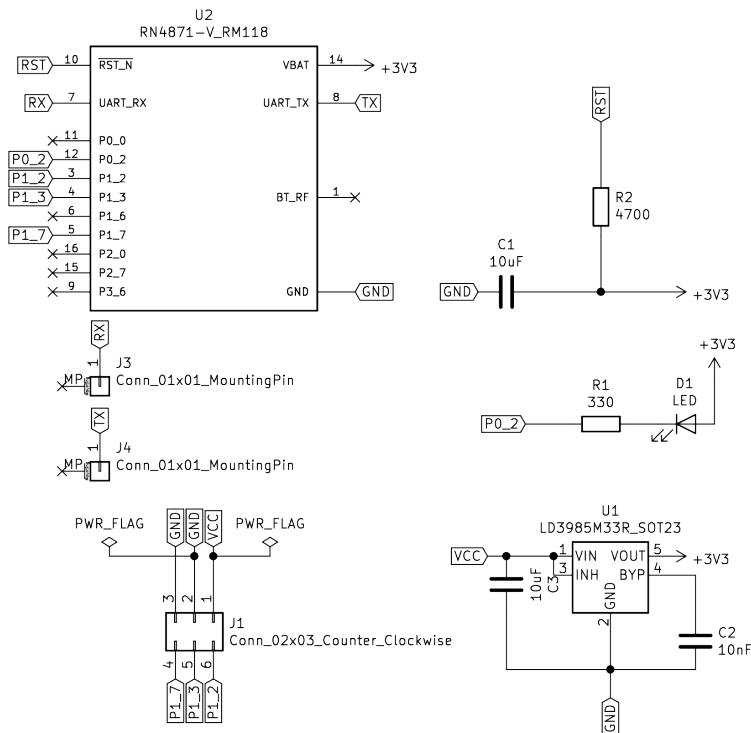

Figure 3.1: The schematics of our custom PCB.

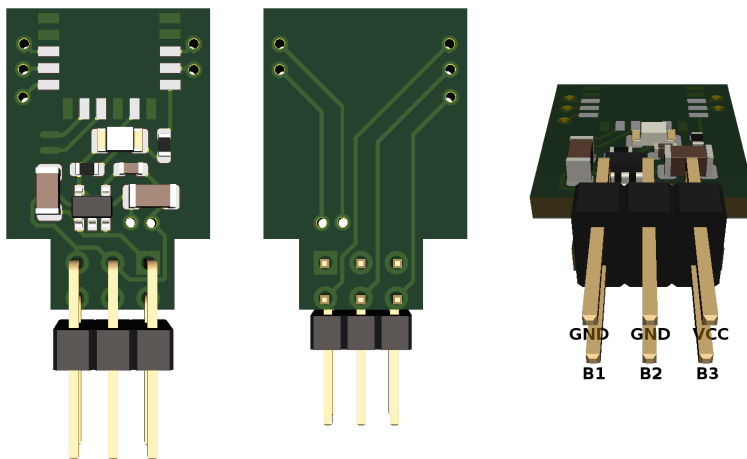

Figure 3.2: Digital layout of our custom PCB from the top, back and front. The order of the pins in the top row from left to right is GND, GND and VCC. The order of the pins in the bottom row from left to right is button 1 to button 3 (B1, B2 and B3).

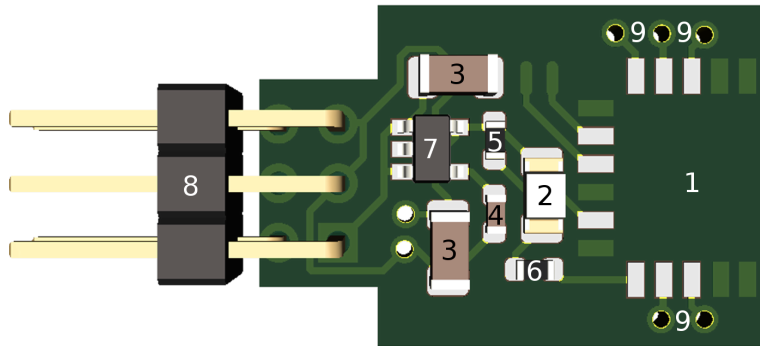

Figure 3.3: Digital layout of the PCB with the indices from Table 3.1.

Due to the size limitations within the ARPen, a double sided PCB is used, as the width is more critical than the length of the board. The dimensions of the PCB without any components are 21.7mm x 14.6mm x 1mm.

The RN4871 exceeds the top edge to ensure that the antenna efficiency is not reduced. We use six pin headers, as we need four pins for the buttons (one for each button and one GND) and two pins for the battery (VCC and GND) that will power the RN4871. To protect our circuit from the voltage fluctuations delivered by our LIPO battery, we include a 3V3 voltage regulator in our circuit. This regulator is required to provide a very low dropout voltage so we can use the battery as long as possible. The LD3985M33R fulfills our requirements. To program the RN4871 we include two pads on the PCB that are connected to the TX and RX pins of the chip. As programming is done exactly once, we save space by not using pin headers for them. When needed, we solder a male-to-male jumper cable to each pad and remove them afterwards.

A voltage regulator protects our circuit from the battery.

3.1.3 Soldering

To make the PCB functional, we solder each component to it. For soldering the small *Surface Mounted Device* (SMD) components to our PCB, we use soldering paste and a re-flow oven. To spread the paste only on the needed parts, we create a stencil for our PCB. To do so, we export

We create a stencil to put soldering paste on the pads.

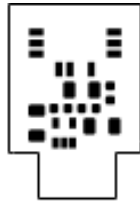

Figure 3.4: The stencil for our PCB. We use this to mask the parts of the PCB where no solder paste is allowed to be.

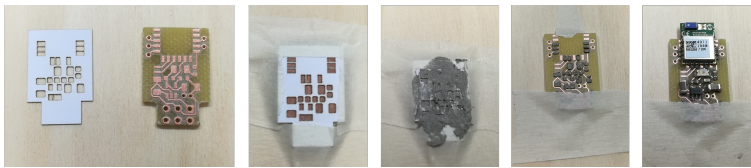

Figure 3.5: We tape the PCB to the table and put the stencil on top. Now only the pads are visible, where we want solder paste to be. After adding the solder paste, we remove the stencil and place all the components on their designated places.

the *Mask Layer* from our PCB in KiCad and delete all pins that are not used. Figure 3.4 shows the stencil. We use a laser cutter to cut the stencil out of paper. We mask our PCB with the stencil and spread the soldering paste. This allows us to only coat the needed pads with solder paste. Figure 3.5 shows this process. However, the legs of the voltage regulator are too close together, so the laser cutter creates a single big hole in the mask for the lower three legs. As the middle leg must not be connected to the other legs, we remove the solder paste between them. We put all components in their place and place the PCB in the re-flow oven. We now solder the pin headers to our PCB.

Superfluous solder paste is removed.

As our PCB mill is able to create double-sided PCBs, but cannot connect both sides, we cut off legs of resistors and solder them onto the PCB from both sides. Afterwards, we cut the bottom side of the PCB as flush as possible. We use a multimeter to ensure that there are no short-circuits on the board. The finished PCB is shown in Figure 3.6. To prevent accidental short-circuits we mask the back of the PCB with tape.

We connect both sides by soldering resistor legs to each side.

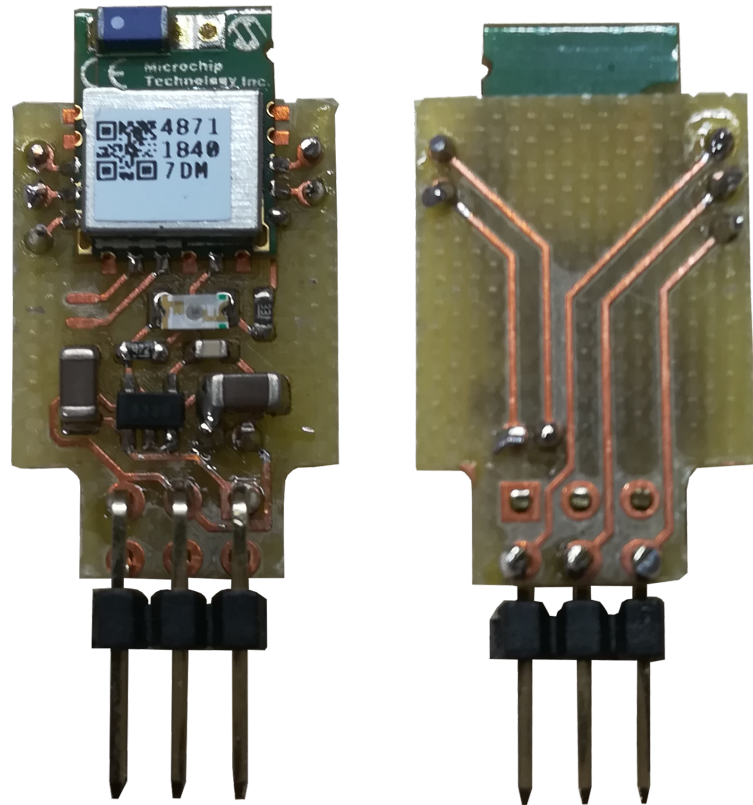

Figure 3.6: The finished PCB after every component is soldered to it.

3.1.4 Connection to a Computer

Solder wires to the TX and RX pad, connect the PCB to the adapter and plug the adapter into the computer.

As this PCB only has pads for *RX* and *TX* instead of pins, we solder a male-to-male jumping cable to each pad. Table 3.2 shows the connections we have to establish between the adapter and our PCB. The setup is displayed in Figure 3.7. Finally we plug the adapter in a USB-port of our computer. A voltage regulator is used to provide a voltage of 3.3V to the board regardless of whether a higher voltage is provided by the USB interface. As soon as the adapter is plugged into our computer, the LED on our PCB flashes. The RN4871 is now sending advertising data, if it has not been modified yet.

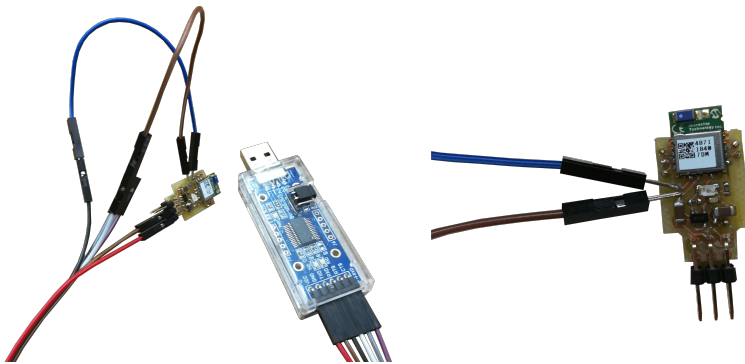

Figure 3.7: Connection between the adapter and our PCB. The upper jumper cable (right) is connected to the RX pin of the RN4871 while the jumper cable below is connected to its TX pin. The adapter is connected to the PCB as described in Table 3.2.

Adapter	PCB
VCC	VCC
GND	GND
TX	RX
RX	TX
RTS	-
CTS	-

Table 3.2: To program the chip we need to connect the adapter to the PCB as shown here.

3.1.5 Scripting

We connect the PCB to a computer using a USB-to-serial adapter as explained in Section 3.1.4 “Connection to a Computer”. The RN4871 is programmed using a python library called `pySerial`³. After installing the library, we establish a connection with the following command:

```
python -m serial.tools.miniterm - 115200
```

The RN4871 requires a baud rate of 115200. The program will now list possible ports to which our adapter could be

We program the RN4871 using `pySerial`.

³<https://pythonhosted.org/pyserial/index.html> (Accessed: 21.02.2020)

```

--- Miniterm on COM20 115200,8,N,1 ---
--- Quit: Ctrl+] | Menu: Ctrl+T | Help: Ctrl+T followed by Ctrl+H ---
CMD> ECHO ON
AOK> PZ
Reboot after Factory Reset
%REBOOT%CMD> ECHO ON
AOK> NA,Z
AOK> SS,00
AOK> WC
AOK> SN,ARPen
AOK> PS,713D0000503E4C75BA943148F18D941E
AOK> PC,713D00002503E4C75BA943148F18D941E,10,07
AOK> SW,0A,09
AOK> SW,0B,0A
AOK> SW,0D,0B
AOK> NA,01,05
AOK> NA,07,1E948DF1483194BA754C3E5000003D71
AOK> NA,08,415250656e
@PIO1HW
SHW,0072,42333a5550
@PIO1L
SHW,0072,42333a444f574e
@PIO2H
SHW,0072,42323a5550
@PIO2L
SHW,0072,42323a444f574e
@PIO3H
SHW,0072,42313a5550
@PIO3L
SHW,0072,42313a444f574e
AOK
AOK> SR,0040
Rebooting
%REBOOT%

```

Figure 3.8: Console output after programming the RN4871 according to Appendix A “RN4871 code”.

We program the RN4871 using our script. This setup is indistinguishable from the old one for the app.

connected. We enter the correct port (in our case COM20) and are now able to program the RN4871. We enter the code as explained in Appendix A “RN4871 code”. Figure 3.8 shows the console output after each line is entered. After the connection is established, we program the RN4871 with our script. The complete script and the explanation for commands used can be found in Appendix A “RN4871 code”. The script configures the advertising data and creates a private characteristic which enables the RN4871 to send data to the connected device. The RN4871 now informs the connected device about each change regarding the states of the buttons.

3.1.6 Buttons and Battery

In order to receive user inputs, we need buttons and a power switch on the ARPen. For this, we use the components listed in Table 3.3.

Index	Component	Amount
1	Omron B3F-1062 6mm x 6mm	3
2	Switch 3.5mm x 8mm	1
3	Flexible thin wires	few
4	LiPo battery 3.7V 31mm x 12mm x 4mm	1

Table 3.3: Components to connect buttons and a power switch to our PCB.

We crimp female headers to every wire that is going to be connected to the PCB. Afterwards we solder the components together as shown in Figure 3.9. One side of each button has a cable with a female pin header crimped to it. Each of these three cables (not GND) is plugged into its place in a 3-socket pin header. We create a GND lane which connects every button to GND. This lane has a female pin header crimped to the longest wire.

We connect all buttons to GND and group the other side of each button in a 3-socket pin header, to keep them in the correct order.

We use the 3-socket pin header to keep the order of the buttons fixed and minimize errors while connecting all parts. We plug everything together in the following order:

1. Plug the socket onto the lower row of our PCB pin headers.
2. Plug the GND-wire onto the most left pin header in the first row.
3. Connect the battery, such that its GND is plugged onto the middle pin of the first row.

We put a switch between the GND of our battery and our PCB, which allows us to toggle the power supply. The switch fits into the rectangular hole on our ARPen.

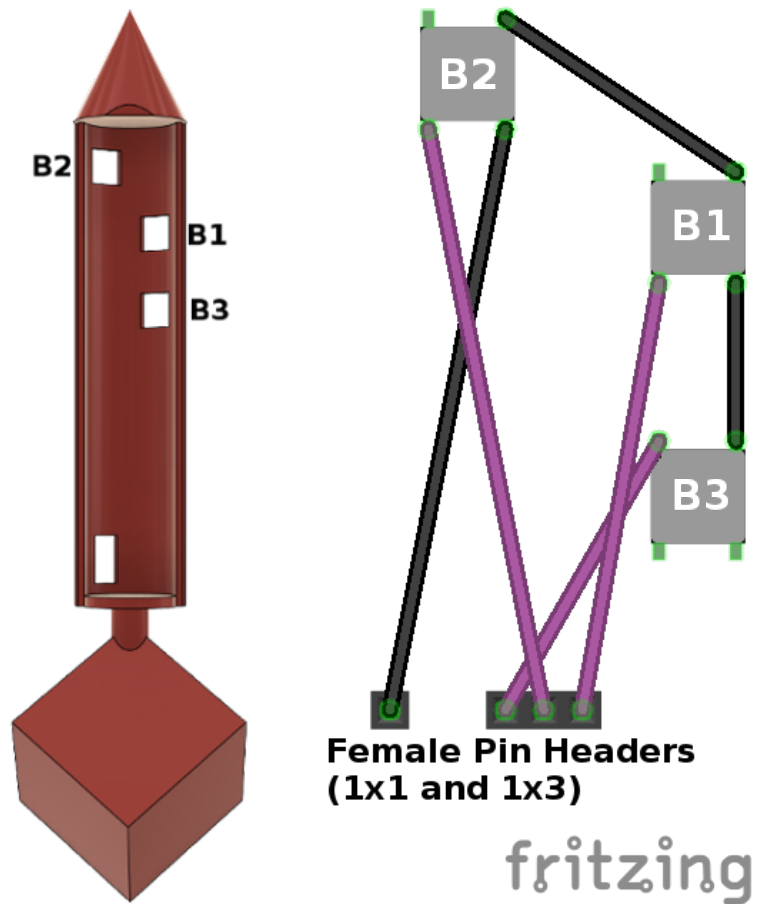

Figure 3.9: Soldering the buttons to connect them to our PCB. Each button (right) is facing down, so it matches the view from the pen (left). We use black for GND. Other colors are put into a female pin header. With this setup, we are able to plug these two female pin headers directly onto our PCB without having to deal with the order of the buttons.

3.1.7 Benefits and Limitations

The hardware changes are indistinguishable for the ARPen app.

We successfully exchanged the *RedBear BLE Nano V2* from the original version of the ARPen with our new setup around the *RN4871*. This change of hardware does not make any difference for the app. The scripting language of the *RN4871* allows us to monitor the button states on the ARPen and may extend its functionality in the future.

Our PCB gives feedback on its Bluetooth connection status. As the app is not consistent on this status to the pen, this allows us to perceive the actual connection status. One flash per time interval by the LED indicates that the chip is running. Two flashes indicate an active connection to a device. Using our new PCB, we are able to relocate all of the hardware from the marker cube to the inside of the pen, which makes the cube independent from the electronics (see Chapter 3.2 “ARPen model”).

The PCB indicates its connection status with an LED.

As the RN4871 only supports three pin trigger functions (see Table A.1), we can only distinguish between three buttons. Adding another button to the ARPen is not possible with this setup.

The RN4871 only supports up to three buttons.

3.2 ARPen model

In addition to introducing our custom PCB we also create a modified version of the ARPen model. The hardware changes we have made (as explained in Section 3.1 “Hardware and Electronics”) enable us to fit all the electronics inside the pen, leaving the marker cube empty. This allows us to easily place the cube on other parts of the pen (see Chapter 4 “Marker Placement”). In this section we explain our design of the ARPen. Furthermore, we show how to add buttons to the ARPen and connect them to our PCB.

3.2.1 Autodesk Fusion 360

We use the *Computer Aided Design, Modeling and Engineering* (CAD, CAM and CAE) software [Autodesk Fusion 360](https://www.autodesk.de/products/fusion-360/overview)⁴ to redesign the ARPen. One main reason for using Autodesk Fusion 360 is its timeline functionality. Each change applied to a model is shown in a timeline on the bottom of the interface. On the one hand, this simplifies getting an overview

Autodesk Fusion 360 has a powerful timeline functionality for applying changes.

⁴<https://www.autodesk.de/products/fusion-360/overview> (Accessed: 21.02.2020)

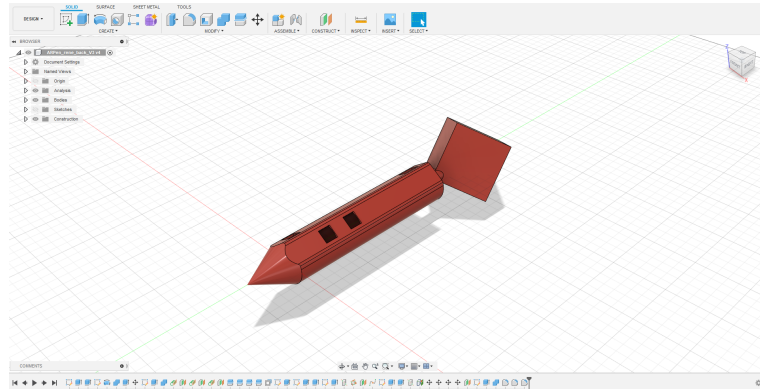

Figure 3.10: The Interface of Fusion 360. The timeline of all performed changes is at the bottom and allows us to iterate through each step and apply changes.

of all modeling stages. On the other hand it enables us to iterate through each step and apply changes. These changes are then applied (if possible) to all of the following steps, which makes corrections easier. Figure 3.10 shows a screenshot of the user interface of Autodesk Fusion 360.

3.2.2 Rebuilding the ARPen

The 3D model of the original ARPen was used as a basis for our redesign. We create our modified version by applying changes to the wall thickness, the position of the hole on the back and the total height, which is currently set by the dimensions of the cube. Figure 3.11 shows the original ARPen in comparison to our modified version. The exact dimensions of our model are listed in Section 3.2.3 “Dimensions”.

We modify the original ARPen to gain enough space for the hardware inside its base.

3.2.3 Dimensions

In order to fit all of the hardware inside the pen, we make some small adjustments to the dimensions of our ARPen in comparison to the original version. We increase the inner diameter from 14mm to 17mm by shrinking the width of

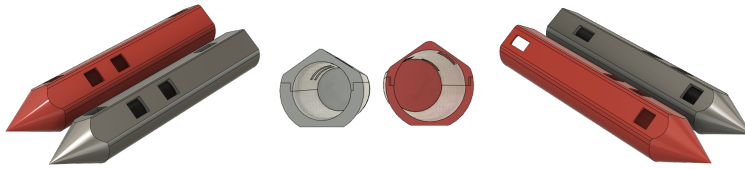

Figure 3.11: Side by side comparison of our modified ARPen (red) and the original ARPen (black) without the cube. We increase the inner diameter by decreasing the thickness of the walls, while maintaining sufficient stability of the ARPen.

the walls. Additionally we increase the height and width of our ARPen by approximately 1.5mm, which affects the outer diameter. The total height is 20mm and the total width is 21mm. The smallest wall thickness is 0.5mm. For the original ARPen this thickness is 1.5mm. Even though we use thinner walls compared to the original ARPen, this does not significantly affect its stability. Each squared hole for the buttons is 6.5mm x 6.5mm. This is sufficient for the buttons to be mounted from the inside of the pen. The rectangular hole is used for the on/off switch. Its size is 5mm x 9mm. This hole is moved closer to the back of the pen so that the switch does not occupy as much space as before. The distance between the hole and the back of the pen (without the cube) is 4mm. The pen has a total length of 166mm, while its base is kept at 90mm. We reduce the size for each side of the cube from 40mm to 30mm. Lower sizes resulted in frequent inaccuracies for the tip of the ARPen. We adapt the markers for the cube and the app according to the new sizes in Chapter 4 “Marker Placement”. Figure 3.12 shows the dimensions of our ARPen.

We increase the inner diameter by thinning the walls. The size of the cube decreases from 40mm to 30mm.

We use a switch to control the power supply.

3.2.4 Printing

We use an Ultimaker 2+ Extended to print the pen with a 4mm nozzle and standard settings including support. The

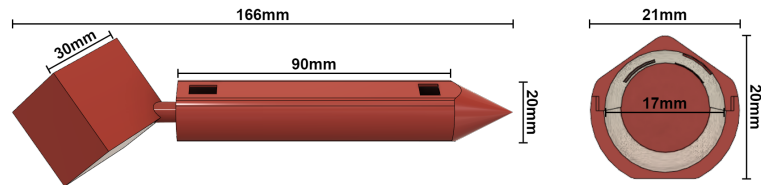

Figure 3.12: The dimension of our ARPen viewed from the side (left) and the back (right). Each squared holes has a size of 6.5mm x 6.5mm, while the rectangular hole has a size of 5mm x 9mm.

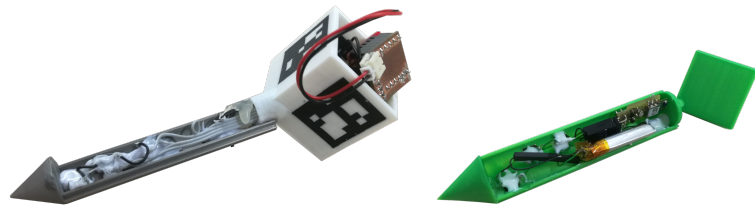

Figure 3.13: The original ARPen (left) in comparison to our ARPen after assembly (right). It is now functional and can be used with our enhancements made to the original app (see Chapter 4.5 “Software Adaption”).

model is sliced with [Ultimaker Cura](https://ultimaker.com/de/software/ultimaker-cura)⁵ version 4.4.0. In the process known as *slicing* Cura creates a file, which the 3D printer is able to read. This file contains all necessary commands to print the selected model as specified. The material we use is polylactide (PLA), which is a common material for 3D printing.

3.2.5 ARPen Buttons

Hot glue is used to hold the buttons in their place and to prevent short-circuits.

The ARPen uses three buttons and one switch. We mount the switch in the rectangular hole, one button in each of the the three square holes, and solder everything as shown in Chapter 3.1.6 “Buttons and Battery”. Each button and the switch is mounted to its designated hole and attached with hot glue. The hot glue is not only used for keeping the

⁵<https://ultimaker.com/de/software/ultimaker-cura> (Accessed: 21.02.2020)

buttons in their place, as it also prevents accidental short-circuits. Figure 3.9 displays the placements of the parts, while Figure 3.13 shows our modified ARPen without its markers (see Chapter 4 “Marker Placement”) in comparison to the original version.

3.2.6 Benefits and Limitations

With our new design we were able to put all parts of the hardware inside the base of the pen. The cube, which is now empty, can be printed directly to the pen. This reduces errors in the marker detection and enables us to use the same wiring within the ARPen when creating other modifications (see Chapter 4.2 “Different ARPens”). Furthermore, the weight of the hardware is now distributed more evenly over the whole pen instead of being focused only in the cube.

Moving the hardware to the inside of the base of the pen has a disadvantage. The inner diameter of the ARPen is now limited by our PCB and the LiPo battery. To further decrease the overall size of the ARPen, smaller hardware is needed.

The hardware is put inside the base of the ARPen which improves the weight distribution and generalizes the process of wiring.

The inner diameter of the ARPen is now limited by the PCB and the battery.

Chapter 4

Marker Placement

In this chapter we focus on the question whether the placement of the cube can be improved. We introduce seven ARPens and explain their benefits and drawbacks. Furthermore, we create a formula to calculate the position of the tip in 3D space for each pen and explain the necessary changes to the app, so it is able to handle our different ARPens.

Having the cube at the back of the pen comes with a disadvantage. The point of interaction within the app is at the tip of the pen, which typically is the focus of the user. If the cube holding the markers gets out of the camera view, the tracking immediately stops. The user has to split his focus between the tip of the pen and the cube, which is unnatural. Figure 4.1 illustrates this problem. One advantage of having the cube at the back is that the users can turn their wrist like they wish and there will most likely be at least one side of the cube visible to the camera.

The user has to split his focus between the cube and the tip of the pen.

4.1 Positions

To figure out which cube positions are possible we have a look at the pen from the side (Figure 4.2). When holding the pen in a hand there is no space underneath the pen, so

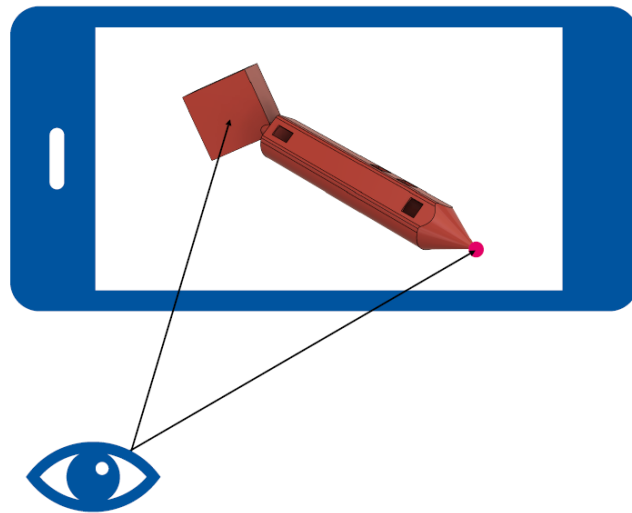

Figure 4.1: When interacting with the ARPen the user has to split his focus between the cube and the tip.



Figure 4.2: Side view on the ARPen. There are not many possible places to move the cube to. We investigate cubes at the *front* and *top* in comparison to the cube at the *back*.

we cannot put the cube there. There are mainly two other possible positions in addition to the current placement. We end up with three placements:

- Back
- Front
- Top

In the next sections we explain the benefits and drawbacks of each placement.

4.1.1 Back

Having the cube at the back of the pen allows a wide range of movement. When moving the pen, there is almost always at least one side of the cube in the view of the camera. This allows continuous tracking and the user does not have to think much about the movements he executes. Still, the user has to split his focus between the tip of the pen and the cube to continue his task. Figure 4.1 illustrates this problem.

A back cube is easy to track, but the user has to split his focus.

4.1.2 Front

Moving the cube to the front lets the user focus entirely on one single point on the screen. Now the cube is as close to the tip as possible. However we now have to face accidental occlusion of the markers. As the cube is now in front of the hand when holding the pen the user can occlude the cube with his hand. The tracking is interrupted each time this happens.

A front cube merges the two focus points, but it is easy to occlude the cube.

4.1.3 Top

Placing the cube on top of the pen grants us some the benefits from both *Back* and *Front*. The cube is visible during most movements and the distance between the two points of focus is decreased. But the user still has to split his focus, even if it is not as much as with having the cube at the *Back*. This approach also shortens the total length of the pen. However, the height of the pen increases and we expect users to find it more difficult to adapt to this approach than to the *Back* and *Front*.

A top cube is a compromise of the advantages of both other cubes, but it increases the height of the pen.

4.1.4 Combining Placements

We also combine placements which use two cubes instead of one.

We also investigate combinations of the three different cube placements. By using two cubes, the app has more information available on the position of the pen. As there are more markers in different positions, the user does not have to take care about the current position of each cube. The chance that at least one side from one cube is in view of the camera is increased with this approach. We do not use three cubes at the same time, as we gain only very little additional information from it (in comparison to using two cubes) and the size of the ARPen would increase a lot. Additionally, users may dislike the idea of having two or more cubes on the pen at the same time. With this approach we gain three more placements:

- BackFront
- BackTop
- TopFront

4.1.5 Combining Different Cube Sizes

We create a modified version of *BackFront* which has a small front cube.

This approach is a modification of the *BackFront* version. We decrease the size of the cube at the front. The idea behind this approach is that if the pen is further away from the camera, the back cube will probably be in the view of the camera. The cube in the front can then be ignored. If the pen is close to the camera, the cube at the back may get out of the view of the camera. But now the cube at the front is big enough to be recognized and can be used for tracking. Furthermore, having a small cube in the front may be more comfortable for the users. In addition, a smaller cube does not collide with the environment as easily as the bigger cube does. This approach adds our last placement for our investigation in Chapter 5 “Study”:

- BackFrontSmall

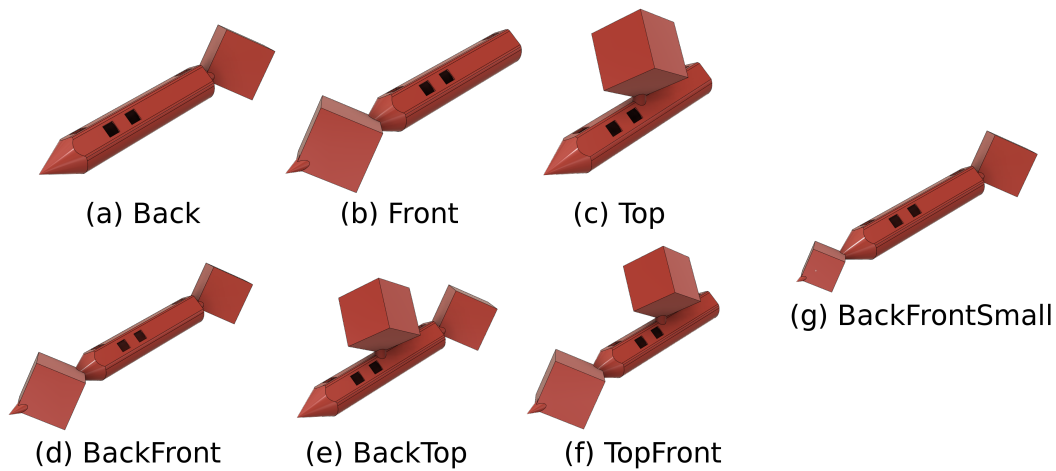

Figure 4.3: The ARPen with different placements of the cube.

4.2 Different ARPens

We use Autodesk Fusion 360 to create each model. Figure 4.3 shows each of the pens, labeled with the name we will use during this thesis.

4.2.1 Cube Orientation

To allow a comfortable use of each ARPen, we take a closer look at cube rotations. The cube at the back is the least critical its rotation. We design it in a way, so that the user can position the lower side of the cube on his wrist if he needs to. However, the orientation of the front cube is important. The lower side of the cube should be parallel to the ground in normal usage to avoid hitting the ground with the edge of the cube. Hitting the Ground would increase the difficulty to work with the pen. The top cube is rotated such that it does not interfere with the users hand.

The cubes are rotated such that they do not hinder the user.

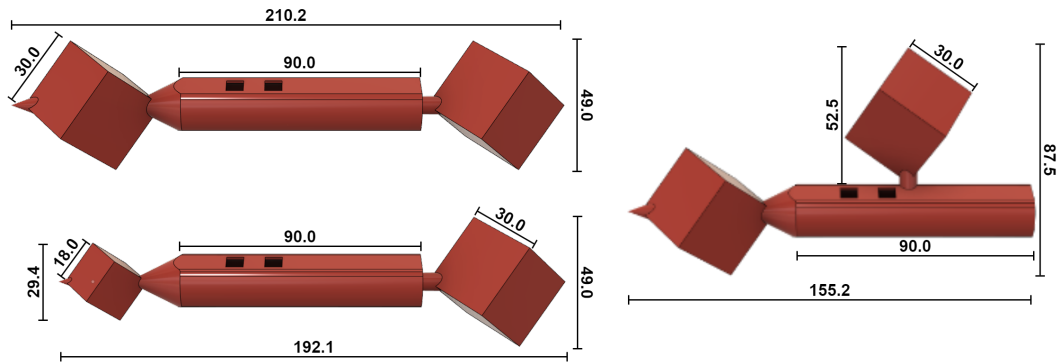

Figure 4.4: The dimensions for of the ARPens. These three models cover all sizes from the different pens in addition to Figure 3.12.

4.2.2 Dimensions

Moving and adding cubes to the pen changes its dimensions. While the base of each pen stays the same, their lengths and heights differ, according to the placements of the cubes. Figure 4.4 includes all sizes. Additionally, all sizes are listed in Table 4.1. We choose the smaller cube to have a side length of 18mm. We evaluated different sizes for this cube and when the cube becomes smaller, the tracking creates heavy jitter for the position of the calculated tip, even when the cube is closer to the camera. Making the cube bigger is not an option, as we already have a *BackFront* pen and there should still be a distinct difference between those two designs. We place the top cube 47mm away from the back end of the pen base. In this way, we move the cube as far to the front as possible without causing an interference between the cube and the users hand.

4.2.3 Printing and Electronics

We slice every model using Cura and print them using an Ultimaker 2+ Extended with a 4mm nozzle using support. The material we use is PLA. We design each pen such that they all share the same base. This allows us to attach the electronics to each pen as explained in Chapter 3.1.6 “Buttons and Battery”.

Pen	Length	Height	Cube Side Length
Back	166.0	49.0	30.0
Front	155.2	49.0	30.0
Top	111.0	72.5	30.0
BackFront	210.2	49.0	30.0
BackTop	166.0	87.5	30.0
TopFront	155.2	87.5	30.0
BackFrontSmall	192.1	49.0	30.0 and 18.0

Table 4.1: The Dimensions for each pen in mm. The total length is measured from the front point to the back point. The total height is measured in the same way.

4.3 Markers

The ARPen uses [ArUco](#)¹ markers to detect and to track the pen. Every side of its cube needs one marker. As we need to distinguish between four different cubes (*Back*, *Front*, *Top* and the *Small* cube), twenty four markers are used in total. The set of markers we use is called ARUCO_MIP_36h12. The size of the markers is 24mm x 24mm, while the size of the small markers is 14.4mm x 14.4mm. Each marker is surrounded by white color, filling the empty space on each side of the cube. As the cylinder which connects the cube to the pen reaches into the three respecting surfaces of the cube, we offset the markers on those surfaces. We have an offset of 1mm in x and y direction for these markers. For the smaller markers, the offset is 0.6mm.

Each cube has its own set of ArUco markers which are used to track the pen.

4.4 Calculating the Virtual Tip

In this section we calculate the position of the tip relative to a given marker. The calculation for a cube in the back is similar to a cube in the front, while we need a different approach for the top cube. The calculation for the back cube was introduced by Wehnert [2018] but included a minor er-

The calculations for the back cube and the front cube are similar.

¹<https://sourceforge.net/projects/aruco/> (Accessed: 16.02.2020)

ror dealing with the offset of the markers. Therefore, we will modify the formula and explain the origin for every value.

4.4.1 Angles

In this section we calculate the values for α and β which we use in Chapter 4.4.2 "Back and Front". Both angles are shown in Figure 4.5. We will use the notations from that figure to explain the values.

As L' is penetrating through the edge of the cube, the following holds:

$$\alpha = 45^\circ \quad (4.1)$$

To calculate β , we think of a triangle formed by A , M and V with a right angle at A . With this setup we calculate the distance d_{AV} between A and V as well as the distance d_{MV} between M and V . For simplicity we assume the cube to have a side length of s :

$$\begin{aligned} d_{AV} &= \frac{\sqrt{s^2 + s^2}}{2} = \frac{s * \sqrt{2}}{2} \\ d_{MV} &= \frac{\sqrt{(2 * d_{AV})^2 + s^2}}{2} = \frac{\sqrt{2 * s^2 + s^2}}{2} = \frac{s * \sqrt{3}}{2} \end{aligned} \quad (4.2)$$

Now we can calculate β :

$$\begin{aligned} \beta &= 90^\circ - \sin^{-1}\left(\frac{d_{AV}}{d_{MV}}\right) \\ &\stackrel{(4.2)}{=} 90^\circ - \sin^{-1}\left(\frac{\frac{s * \sqrt{2}}{2}}{\frac{s * \sqrt{3}}{2}}\right) \\ &= 90^\circ - \sin^{-1}\left(\frac{\sqrt{2}}{\sqrt{3}}\right) \\ &= 90^\circ - 54.74^\circ \\ &= 35.26^\circ \end{aligned} \quad (4.3)$$

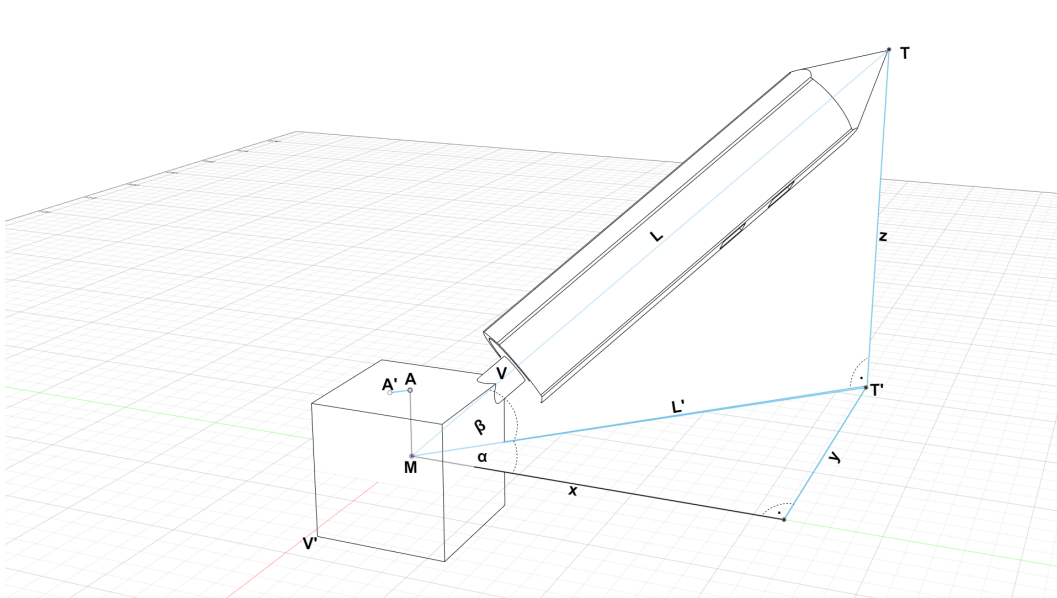

Figure 4.5: This sketch includes the necessary values we use to calculate the position of the tip. We know the offset from A' to A and the offset from A to M . Furthermore, we know the angles α and β as well as L . With these values we calculate the tip T . The path to the tip is $A'AMT$.

4.4.2 Back and Front

We define the orientation of the pen as shown in Figure 4.5. Furthermore, we use the following definitions:

- M is the middle of the cube
- T is the tip of the pen
- T' is the tip of the pen T with the z coordinate of M :

$$\begin{pmatrix} T_x \\ T_y \\ M_z \end{pmatrix}$$
- L is the distance between M and T
- L' is the distance between M and T'
- A is the middle of the face of the current marker
- A' is the position of the detected marker

- α is the angle between L' and x
- β is the angle between L' and L
- $offX$ is the marker offset in x direction
- $offY$ is the marker offset in y direction
- $cubeLength$ is the side length of the cube
- V is the vertex of the cube that is closest to the pen base
- V' is the vertex of the cube that is furthest away from the pen base

We obtain the relative vector \vec{x} from A' to T according to the following formula:

$$\vec{x} = \vec{x}_{off} + \vec{x}_{tip}, \quad (4.4)$$

with \vec{x}_{off} being the vector from A' to M and \vec{x}_{tip} being the vector from M to T .

Back

For the calculation we split the faces of the cube into two groups containing three faces each.

We split the six faces of the cube into two groups. The first group contains the three faces that are closest to the pen base and that are able to be positioned as shown in Figure 4.5. They all share the vertex V . We call this group *Close Group*. The other group is called *Far Group*. They can all be positioned with the same x and y alignment as the *Close Group*, but with a mirrored z value. They share the vertex V' .

We begin by calculating the vectors \vec{x}_{off} and \vec{x}_{tip} for the *Close Group*. Within this group the markers are offset in x and y direction because of the cylinder connecting the cube to the pen. We obtain the offset vector by reversing the marker offset and setting the z value to half of the side length of the cube:

$$\vec{x}_{off} = \begin{pmatrix} -offX \\ -offY \\ -\frac{cubeLength}{2} \end{pmatrix} \quad (4.5)$$

We need the value L' to calculate the vector \vec{x}_{tip} :

$$L' = L * \cos(\beta) \quad (4.6)$$

We calculate each component of \vec{x}_{tip} using trigonometry and our knowledge from Chapter 4.4.1 “Angles”:

$$\begin{aligned} x &= L' * \cos(\alpha) \stackrel{(4.6)}{=} L * \cos(\beta) * \cos(\alpha) \stackrel{(4.1), (4.3)}{=} \frac{L * \cos(35.26^\circ)}{\sqrt{2}} \\ y &= L' * \sin(\alpha) \stackrel{(4.6)}{=} L * \cos(\beta) * \sin(\alpha) \stackrel{(4.1), (4.3)}{=} \frac{L * \cos(35.26^\circ)}{\sqrt{2}} \\ z &= L * \sin(\beta) \stackrel{(4.3)}{=} L * \sin(35.26^\circ) \end{aligned} \quad (4.7)$$

We calculate \vec{x} for the *Close Group*:

$$\vec{x} = \vec{x}_{off} + \vec{x}_{tip} \stackrel{(4.5) \text{ to } (4.7)}{=} \begin{pmatrix} -offX \\ -offY \\ -\frac{cubeLength}{2} \end{pmatrix} + \begin{pmatrix} \frac{L * \cos(35.26^\circ)}{\sqrt{2}} \\ \frac{L * \cos(35.26^\circ)}{\sqrt{2}} \\ L * \sin(35.26^\circ) \end{pmatrix} \quad (4.8)$$

For the *Far Group* the z coordinate of \vec{x}_{tip} has to be multiplied by -1 . Figure 4.6 illustrates this need. As these markers have no offset in x and y direction, the respective vectors for the *Far Group* are:

$$\begin{aligned} \vec{x}_{off} &= \begin{pmatrix} 0 \\ 0 \\ -\frac{cubeLength}{2} \end{pmatrix} \\ \vec{x}_{tip} &= \begin{pmatrix} \frac{L * \cos(35.26^\circ)}{\sqrt{2}} \\ \frac{L * \cos(35.26^\circ)}{\sqrt{2}} \\ -L * \sin(35.26^\circ) \end{pmatrix} \end{aligned} \quad (4.9)$$

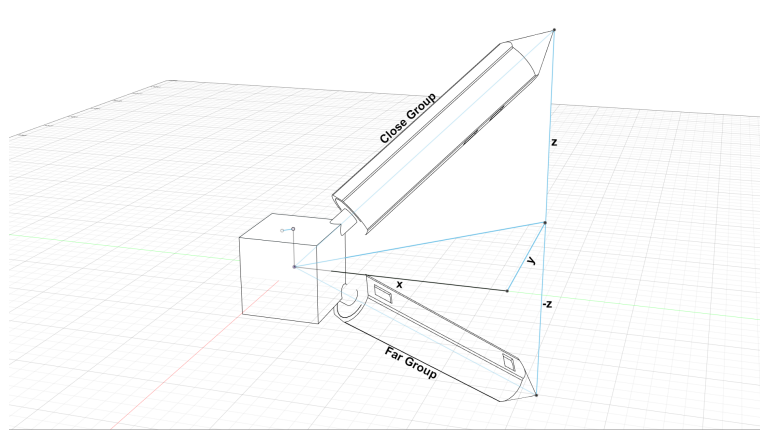

Figure 4.6: The faces of the cube in the *Close Group* and the *Far Group* are sharing the x and y coordinates of \vec{x}_{tip} . For the *Far Group* the z coordinate has to be multiplied by -1 .

Front

The calculation for the front cube uses the same vectors \vec{x}_{off} and \vec{x}_{tip} as the previous calculations. We multiply \vec{x}_{tip} by -1 so it points to the tip of the front cube. Therefore, we obtain the following vector:

$$\vec{x} = \vec{x}_{off} - \vec{x}_{tip} \quad (4.10)$$

4.4.3 Top

The calculation for the top cube is more complex than the calculations for the other cubes. In addition to the variables defined in Chapter 4.4.2 “Back and Front”, we now use Figure 4.7 as our reference and define changes in the variables as follows:

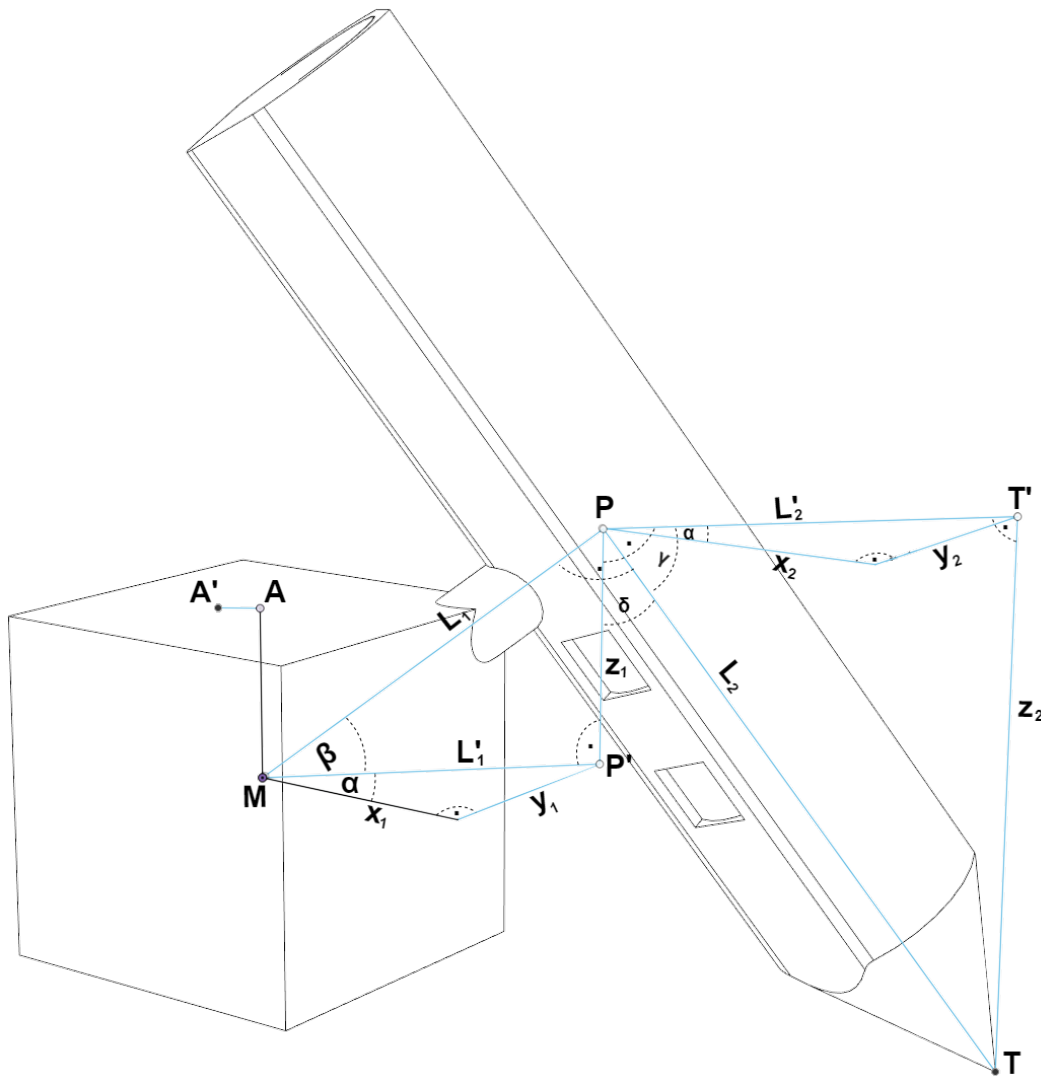

Figure 4.7: This sketch includes the necessary values we use to calculate the position of the tip. We know the offset from A' to A and the offset from A to M . Furthermore, we know the angles α , β , γ and δ as well as L_1 and L_2 . With these values we calculate the tip T . The path to the tip is $A'AMPT$, while PT has to be rotated according to the orientation of the pen. Figure 4.8 shows all used triangles.

- P is the point in the middle of the pen base directly underneath the cube

- P' is P with the z coordinate of M :
$$\begin{pmatrix} P_x \\ P_y \\ M_z \end{pmatrix}$$

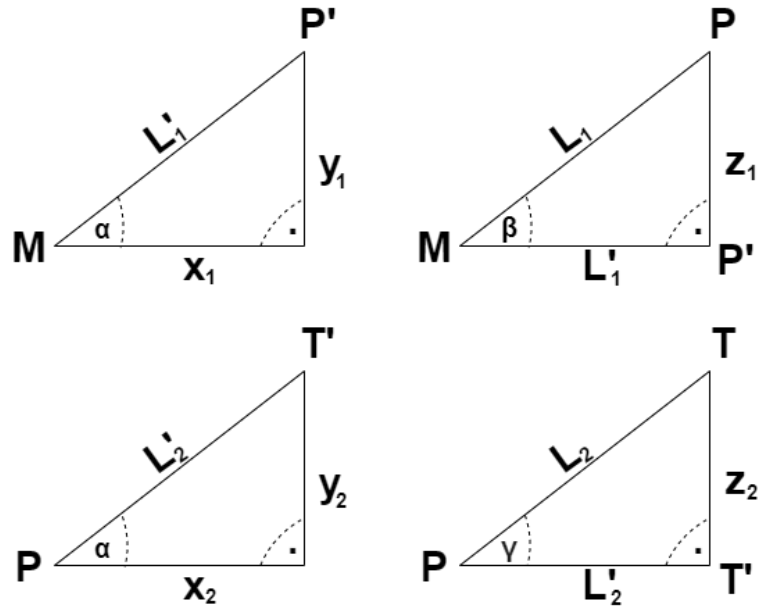

Figure 4.8: A 2D sketch of each triangle shown in Figure 4.7. We use these triangles to calculate the vector from the middle of the cube M to the tip of the pen T . Both triangles on the left are in the same plane within the coordinate system. Same holds for both triangles on the right.

- T is the tip of the pen
- T' is T with the z coordinate of P : $\begin{pmatrix} T_x \\ T_y \\ P_z \end{pmatrix}$
- L_1 is the distance between M and P
- L'_1 is the distance between M and P'
- L_2 is the distance between P and T
- L'_2 is the distance between P and T'
- α is the angle between L'_1 and x_1 and the angle between L'_2 and x_2
- β is the angle between L'_1 and L_1
- γ is the angle between L'_2 and L_2
- δ is the angle between the triangles MPP' and PTT'

As the rotation of the pen is now important, we only need the separation in the *Close Group* and *Far Group* to pick the correct offset vector \vec{x}_{off} as described in Chapter 4.4.2 “Back and Front”. We also calculate \vec{x}_{tip} as before, but we set L to be the distance between M and P . This vector is now pointing at P instead of T . Therefore, we call this vector \vec{x}_p from here on. The calculation is the same for each side of the cube. The vector from P to T is influenced by the rotation of the pen in relation to the seen marker. We call this vector \vec{x}_{rot} . First, we calculate \vec{x}_{rot} for one side and derive the vectors for the other sides from it. In general, the formula we obtain is

$$\vec{x} = \vec{x}_{off} + \vec{x}_p + \vec{x}_{rot}, \quad (4.11)$$

where \vec{x}_{off} depends on the group of the marker, while \vec{x}_p is the same for all markers. We do not give the formulas for these two vectors again, as they are fully covered in Chapter 4.4.2 “Back and Front”. With the current labeling the vectors for the *Close Group* are:

$$\begin{aligned} \vec{x}_{off} &= \begin{pmatrix} -offX \\ -offY \\ -\frac{cubeLength}{2} \end{pmatrix} \\ \vec{x}_p &= \begin{pmatrix} \frac{L_1 * \cos(35.26^\circ)}{\sqrt{2}} \\ \frac{L_1 * \cos(35.26^\circ)}{\sqrt{2}} \\ L_1 * \sin(35.26^\circ) \end{pmatrix} \end{aligned} \quad (4.12)$$

The respective vectors for the *Far Group* are:

$$\begin{aligned} \vec{x}_{off} &= \begin{pmatrix} 0 \\ 0 \\ -\frac{cubeLength}{2} \end{pmatrix} \\ \vec{x}_p &= \begin{pmatrix} \frac{L_1 * \cos(35.26^\circ)}{\sqrt{2}} \\ \frac{L_1 * \cos(35.26^\circ)}{\sqrt{2}} \\ -L_1 * \sin(35.26^\circ) \end{pmatrix} \end{aligned} \quad (4.13)$$

We calculate \vec{x}_{rot} for the upper side of the cube shown in Figure 4.7. For simplicity we add a sketch (Figure 4.8) containing all necessary triangles. First we calculate δ and γ . We know that the other angle within the triangle MPP' is $90^\circ - \beta$. This angle forms a right angle together with δ , so the following holds:

$$\delta = 90^\circ - (90^\circ - \beta) = \beta \stackrel{(4.3)}{=} 35.26^\circ \quad (4.14)$$

We use the calculation of the back cube and adapt it to the situation. We then add a vector for the rotation.

As γ and δ also form a right angle, the following holds as well:

$$\gamma = 90^\circ - \delta \stackrel{(4.14)}{=} 54.74^\circ \quad (4.15)$$

We need the formula for L'_2 to calculate \vec{x}_{rot} :

$$L'_2 = L_2 * \sin(\gamma) \quad (4.16)$$

We calculate each component of \vec{x}_{rot} using trigonometry and our knowledge of all the angles:

$$\begin{aligned} x_2 &= L'_2 * \cos(\alpha) = L_2 * \cos(\gamma) * \cos(\alpha) \stackrel{(4.1), (4.15)}{=} \frac{L_2 * \cos(54.74^\circ)}{\sqrt{2}} \\ y_2 &= L'_2 * \sin(\alpha) = L_2 * \cos(\gamma) * \sin(\alpha) \stackrel{(4.1), (4.15)}{=} \frac{L_2 * \cos(54.74^\circ)}{\sqrt{2}} \\ z_2 &= L_2 * \sin(\gamma) \stackrel{(4.15)}{=} L_2 * \sin(54.74^\circ) \end{aligned} \quad (4.17)$$

As the final vector from P to T is directed towards the negative z axis, we need to multiply z_2 for this side by -1 . Therefore, the complete formula for the given side of the marker is:

$$\begin{aligned} \vec{x} &= \vec{x}_{off} + \vec{x}_p + \vec{x}_{rot} \\ &\stackrel{(4.12)}{=} \begin{pmatrix} -offX \\ -offY \\ -\frac{cubeLength}{2} \end{pmatrix} + \begin{pmatrix} \frac{L_1 * \cos(35.26^\circ)}{\sqrt{2}} \\ \frac{L_1 * \cos(35.26^\circ)}{\sqrt{2}} \\ L_1 * \sin(35.26^\circ) \end{pmatrix} + \vec{x}_{rot} \\ &\stackrel{(4.17)}{=} \begin{pmatrix} -offX \\ -offY \\ -\frac{cubeLength}{2} \end{pmatrix} + \begin{pmatrix} \frac{L_1 * \cos(35.26^\circ)}{\sqrt{2}} \\ \frac{L_1 * \cos(35.26^\circ)}{\sqrt{2}} \\ L_1 * \sin(35.26^\circ) \end{pmatrix} + \begin{pmatrix} \frac{L_2 * \cos(54.74^\circ)}{\sqrt{2}} \\ \frac{L_2 * \cos(54.74^\circ)}{\sqrt{2}} \\ -L_2 * \sin(54.74^\circ) \end{pmatrix} \end{aligned} \quad (4.18)$$

We use the labeling shown in Figure 4.9. We assume that the markers are rotated on the cube so that they match the coordinate system when placed on top, with the cylinder attached to the pen base in the top right corner (lower right for the *Far Group*). Figure 4.10 shows these rotations together with the index used in Figure 4.9. Table 4.2 “Rotation vectors for the calculation of the pen tip.” shows how to compute \vec{x}_{rot} using the respective components x_2 , y_2 and z_2 from Equation 4.17. As $x_2 = y_2$, we only use x_2 for the rotations.

We calculated the rotation vectors for each face of the cube.

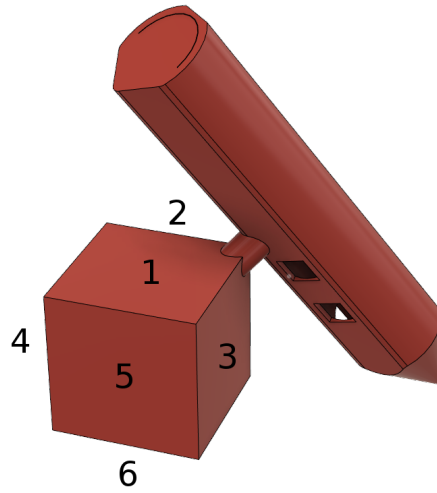

Figure 4.9: We label each side of the cube to match the indices given in Table 4.2.

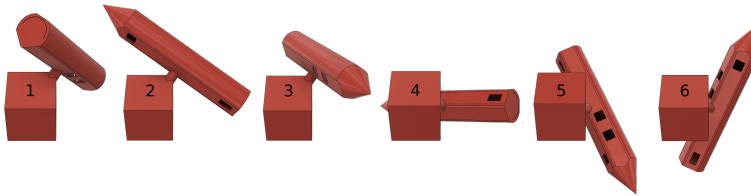

Figure 4.10: The orientation of each side of the cube for which our calculation applies. The labeling is according to Figure 4.9.

Index	1	2	3	4	5	6
x_2	x_2	$-z_2$	x_2	$-z_2$	x_2	x_2
y_2	x_2	x_2	$-z_2$	x_2	$-z_2$	x_2
z_2	$-z_2$	x_2	x_2	$-x_2$	$-x_2$	z_2

Table 4.2: Rotation vectors for the calculation of the pen tip.

4.5 Software Adaption

The app now looks
for two different
marker sizes.

After creating the new ARPenS, we now integrate them into the app. Since the sizes within the app are given in meter, we set the marker size to 0.0240 and create a new variable for the smaller markers with a value of 0.0144. The method that is detecting the markers has to be called with a specific marker size. Therefore, we now call `mDetector.detect(...)` once for each marker size. We use the correct markers from each array to calculate their 3D coordinates by using the function `get3DPoints(size)`, which needs the respective marker size. Afterwards we are able to add the *translations*, *rotations* and *IDs* for each found marker as before.

We add all new
markers to the app
and make the
ARPenS
distinguishable.

We alter the file `MarkerBox.swift`. First we increase the size of the `markerArray` by 12 because of the additional markers used. We introduce an enum `Model`, which consists of one variable for each of our ARPenS. In addition we create a local variable holding the enum value of the current pen. We also add a setter for the `model`. This variable helps us to determine which vectors we have to calculate to get the position of the virtual tip. We add indices for all new markers to the enum `MarkerFace`.

In the function `calculatePenTip(length: Double)` we set the following variables, which are given in meters:

- `cubeSideLength: Double = 0.03`
- `cubeSideLengthSmall: Double = 0.018`
- `markerOffset: Double = 0.001`
- `markerOffsetSmall: Double = 0.0006`

The position of the tip
is calculated based
on the used pen.

With the `model` we select the cubes of the current pen and calculate each vector to the tip according to Chapter 4.4 “Calculating the Virtual Tip” and according to the specifications within the app. We only include the offset vector when it is necessary. As we explained in Chapter 4.3 “Markers”, this is the case for those faces of the

cube that must be offset due to the cylinder which connects the cube to the pen. Afterwards, we iterate through the `markerArray` and save the position of the tip (which was calculated from the position of the found markers) using the enum `MarkerFace`. We now average over all found positions if their deviation does not exceed a predefined threshold as before.

We create a plugin for each pen with a menu entry. On activation, it sets the `model` variable within the `MarkerBox` using the method `setModel(...)`. Afterwards it calls the method `calculatePenTip(...)`, because otherwise the changed model would not be recognized properly.

The user can select the ARPen which he wants to use.

Chapter 5

Study

In this chapter we evaluate the effects different marker placements have on the subjective judgment of users. We use the different pens we created in Chapter 4 “Marker Placement” and conduct a study. Within the study, the participants use each pen and assess which of the seven pens they like the most.

5.1 Aim

We investigate how our different marker placements work for users. Therefore, participants use each pen and fill out a questionnaire. Our aim is to collect feedback on all ARPens we created, to create a ranking among them and to gain knowledge about improvements the ARPen will benefit from.

5.2 Participants

28 people (16 male, 12 female, 2 left-handed) with an average age of 23 years (20-28 years, SD: 2.0 years) participated in our study.

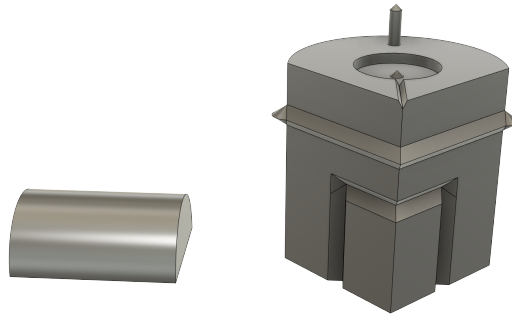

Figure 5.1: The participants draw paths on these objects during the study. These paths include usual movements which users perform with the ARPen.

5.3 Apparatus

For our study we use an iPhone 11, which has a size of 150.9mm x 75.7mm x 8.3mm with a display diagonal length of 6.1". The camera has a resolution of 12. megapixel, while the display has a resolution of 1792 x 828 pixels. The iPhone has a weight of 194g. It uses the A13 chip from Apple.

5.4 Task

The participant has to redraw one out of two given paths on a 3D object, as shown in Figure 5.1. Before the participants begin their trial, the virtual tip of the ARPen on the iPhone is colored in orange. As soon as the third button of the ARPen is pressed, the trial begins. Now the participant redraws the given path using the pen he is given. When finished, he presses the third button of the ARPen again. This changes the color of the tip to green, which indicates that the trial is complete. The participant repeats the task for each pen. Between the trials the participant is allowed to take breaks.

Each participant
uses each pen on a
real object.

5.5 Experimental Design

As we need the participants to subjectively compare the different pens, we use a *within-subject* design. We counterbalance the different pens using a *Latin Square* and randomize which of the two paths the participant has to draw for each pen.

5.6 Study Procedure

When the participant enters the room, they are greeted by the conductor. The participant reads the consent form, which is additionally explained by the conductor. The participant is told that he is allowed to take breaks and drink between the trials but cannot interrupt a trial once it has started. The conductor introduces the ARPen and explains how to use it. The participant is allowed to practice with each pen before the corresponding trial.

Before the first trial, the participant answers the first page of the questionnaire (Appendix B “Study Material”). The ID is contributed by the conductor. Afterwards the conductor shows the path to the participant which he has to redraw with the pen. When the participant is ready, the first trial begins. He performs the current task as explained in Chapter 5.4 “Task”. After each task, the conductor makes sure that all data is saved correctly and prepares the app for the next task by emptying the current scene and selecting the plugin for the next pen the participant will use. Between the tasks the participant answers the questionnaire regarding the pen he used during the task.

During the trials the menu within the app does not take any input by the participant. This prevents the participant from accidentally touching an icon in the menu, which could interrupt the trial.

The participant is allowed to take breaks between the trials.

After each task the participant answers a questionnaire about the pen he used.

5.7 Measurements

This study is intended to gather information on the subjective opinion the participants have on the pens we built. We create a questionnaire (B “Study Material”) to fulfill this purpose. Furthermore, we use the built-in record manager of the app to save data points from the drawn paths. These data points may be analyzed in future research.

5.7.1 AttrakDiff 2

We calculate the pragmatic quality of each pen with the *AttrakDiff 2* questionnaire.

After each task, the participants answers a part of our questionnaire. This questionnaire includes the pragmatic quality measurement from the *AttrakDiff 2* questionnaire which was introduced by Hassenzahl et al. [2003]. We randomize the order of all items and the polarity of each item. For the English version of the questionnaire, we use the same translations as Hassenzahl [2004].

5.7.2 Post-Study System Usability Questionnaire

In addition to the pragmatic quality measurements, we include questions from the *Post-Study System Usability Questionnaire* from Lewis [1992] to gain more knowledge about the handling of each pen.

5.8 Results

In the following we will list the results we collected from the questionnaire. This includes a ranking of all pens, their pragmatic quality, results from the few questions from the *Post-Study System Usability Questionnaire* and comments from the participants.

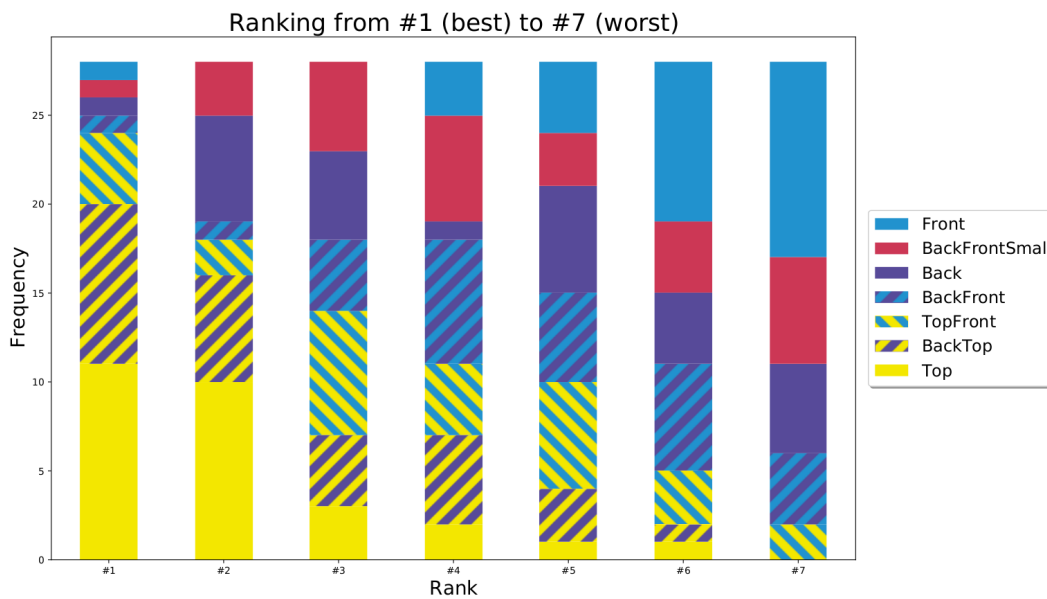

Figure 5.2: Rank distribution of all ARPens from rank 1 (left) to rank 7 (right).

5.8.1 Global Ranking

The results from the ranking of all pens are shown in Figure 5.2. *Top* was placed on the first rank most often, followed by *BackTop*. The same holds for the second rank. *TopFront* was also rated relatively high. *Front* was placed on the last rank and second to last rank most of the time. The other pens vary in their placing. All pens with a cube on the top were placed mainly in the upper ranks with a decreasing trend towards the lower ranks. A Friedman test revealed a significant effect of the pens on the ranking ($X^2(6) = 57.857, p < .001$).

Top achieved the highest rank, followed by *BackTop*, while *Front* reached the lowest rank.

A post-hoc test using Wilcoxon Signed-rank tests with the Bonferroni correction showed the significant differences between the groups listed in Table 5.1. Other differences were not significant with $p > .05$. *Top* had significant differences to every other pen, except from *BackTop*, which achieved the second best overall ranking.

Top had significant differences to every other pen, except from *BackTop*.

AR Pens	p-value	Z	r
Top - Back	$p < .001$	-4.11	0.39
Top - BackFront	$p < .01$	-3.62	0.34
Top - TopFront	$p < .05$	-2.99	0.28
Top - BackFrontSmall	$p < .01$	-3.69	0.35
Top - Front	$p < .001$	-4.62	0.44
BackTop - BackFront	$p < .01$	-3.59	0.34
BackTop - Front	$p < .001$	-4.11	0.39
TopFront - Front	$p < .05$	-3.07	0.29
BackFrontSmall - Front	$p < .05$	-3.27	0.31

Table 5.1: Results from Wilcoxon Signed-rank tests with Bonferroni correction for the ranking of all AR Pens. Differences between non-listed pairs were not significant with $p > .05$.

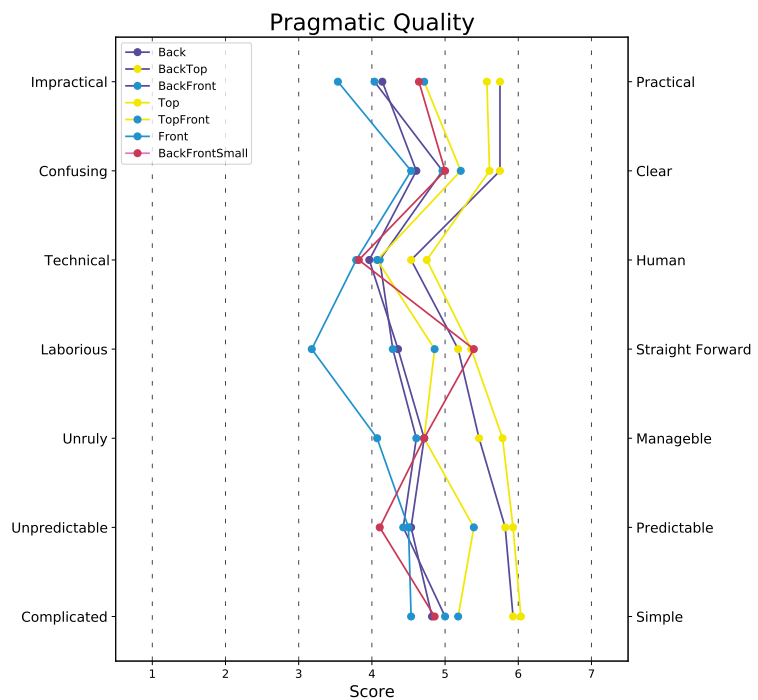

Figure 5.3: Pragmatic Quality according to the AttrakDiff 2 questionnaire for all AR Pens. All graphics are shown individually in Appendix B “Study Material” (Figures B.3 and B.4).

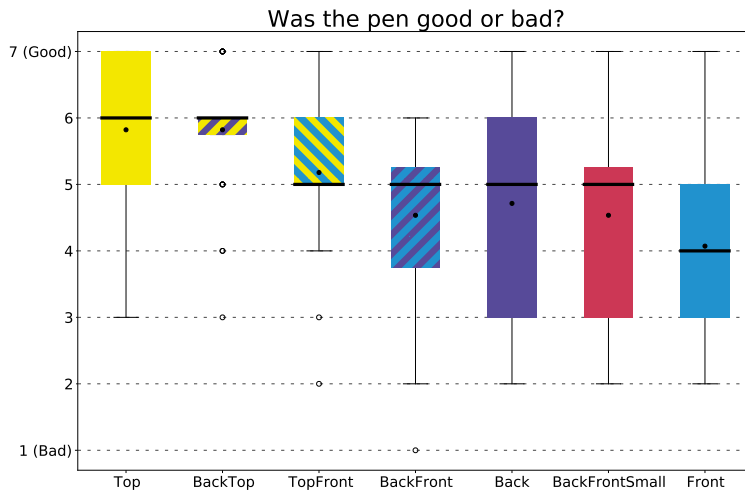

Figure 5.4: The evaluational construct *Bad - Good* from the questionnaire. Black bars represent the median, while black dots visualize the mean for each pen.

5.8.2 AttrakDiff 2

The results of the AttrakDiff 2 questionnaire are visualized in Figure 5.3, while the pragmatic quality for each ARPen is listed in Table 5.2. All graphics are shown individually in Appendix B.2 “Results”.

ARPen	Pragmatic Quality	SD
Top	5.577	0.907
BackTop	5.490	0.941
TopFront	4.878	0.905
BackFrontSmall	4.648	1.105
BackFront	4.490	1.201
Back	4.449	1.242
Front	4.030	1.237

Table 5.2: Pragmatic quality of all ARPens according to the AttrakDiff 2 questionnaire.

As in the global ranking, *Top* reached the first rank with a pragmatic quality of 5.577, followed by *BackTop* with a pragmatic quality of 5.490. *TopFront* has the third high-

ARPens	p-value	Z	r
Top - Back	$p < .01$	-3.49	0.33
Top - BackFront	$p < .01$	-3.57	0.34
Top - BackFrontSmall	$p < .05$	-2.95	0.28
Top - Front	$p < .001$	-4.38	0.41
BackTop - BackFront	$p < .05$	-2.99	0.28
BackTop - Front	$p < .001$	-3.85	0.36

Table 5.3: Results from Wilcoxon Signed-rank tests with Bonferroni correction for the pragmatic quality of all ARPens according to the AttrakDiff 2 questionnaire. Differences between non-listed pairs were not significant with $p > .05$.

Pens with a top cube achieved the three highest pragmatic qualities, while *Front* has the lowest pragmatic quality.

est score, but is close to the next pens. With a pragmatic quality of 4.030, *Front* is placed last. These four pens are ranked exactly as in the global ranking. Figure 5.3 shows that *Top* and *BackTop* outrank every other pen in every category, except *BackFrontSmall's* score regarding *Laborious - Straight Forward*. *TopFront* also outranks most of the other pens, but not as much as *Top* and *BackTop*. *Front* has the lowest score in every category, except from *Unpredictable - Predictable*, where *BackFrontSmall* has the lowest score. A Friedman test revealed a significant effect of the pens on the pragmatic quality ($X^2(6) = 39.842, p < .001$).

Top has significant differences to every pen, that does not have a top cube.

A post-hoc test using Wilcoxon Signed-rank tests with Bonferroni correction showed the significant differences between the groups listed in Table 5.3. Other differences were not significant with $p > .05$. *Top* had significant differences to every other pen, except from *BackTop* and *TopFront*, which achieved the second and third best overall pragmatic quality. *Front* has the lowest pragmatic quality among all pens.

Figure 5.4 shows the evaluational constructs from the questionnaire (*Bad - Good*) mentioned by Hassenzahl [2004] for all ARPens. The median is displayed by a black bar, while a dot represents the mean. Overall, pens with a cube on the top reached a higher score than pens without one.

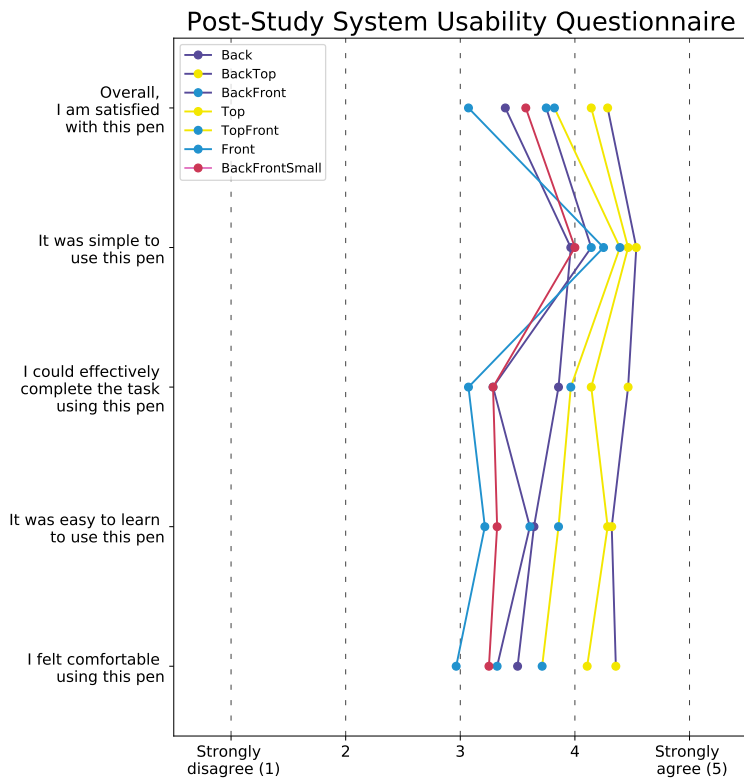

Figure 5.5: Post-Study System Usability questionnaire results for all ARPens. All graphics are shown individually Appendix B “Study Material” (Figures B.1 and B.2).

5.8.3 Post-Study System Usability Questionnaire

The results from the questions we used from the *Post-Study System Usability Questionnaire* are shown in Figure 5.5 and indicate that pens with a cube on the top were more liked by the participants and were easier to handle. These results coincide with the results from the global ranking and the scores from the pragmatic qualities of the ARPens. As before, *Front* has the lowest rating among all pens.

The results coincide with the global rankings and the pragmatic qualities.

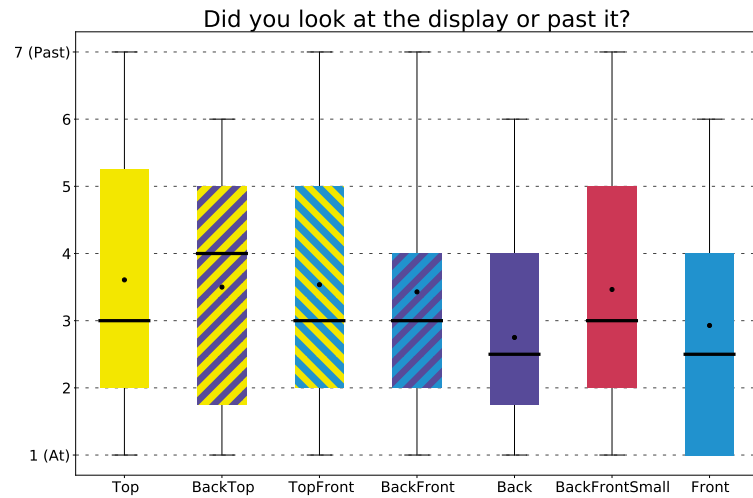

Figure 5.6: During the tasks the participants tended to look more at the display than past it.

5.8.4 Display

During the tasks the participants looked more on the display than past it, as shown in Figure 5.6. This is because they had to keep at least one marker within the camera view. *Front* close to *On the display*, because the participants often occluded the markers with their own hand and had to look at the display to prevent this from happening. *BackTop* has the highest median among all ARPen, being exactly in the middle.

Participants looked more often at the display than past it.

5.8.5 Comments

In the following, we summarize the most common remarks of the participants for each ARPen.

Top

It was easy for the participants to keep the markers within camera view (20x) and the pen was easy to handle (6x).

Some participants struggled with the balancing of the pen, due to the top cube (2x). To improve the pen, a smaller cube would be beneficial (3x).

BackTop

It was easy for the participants to keep the markers within camera view (16x) and it was easy to draw around objects (3x). Sometimes the position of the top cube was disturbing (4x). To improve the pen, a smaller cube would be beneficial (2x).

TopFront

It was easy for the participants to keep the markers within camera view (10x), but the front cube was in the way (8x) and also occluded the view on the tip (2x).

BackFront

It was easy for the participants to keep the markers within camera view (6x), but the tip of the pen was occluded (6x) and the front cube was in the way (6x).

Back

For some participants, this pen felt most like a real pen (3x), it was easy to keep the markers within camera view (3x) and it was easy to draw around objects (3x). Furthermore, the participants liked that the tip is visible (3x). They did not like that they had to split their focus between the tip and the cube (8x), which let the marker slip out of the camera view (8x). Some participants complained about the length of the pen (5x).

The distance between the tip and the cube splits the focus of the participants

BackFrontSmall

The participants liked the idea of the small front cube (11x) and mentioned that it was easy to keep the markers within camera view (5x). Still the front cube was in the way (5x) and some participants lost track of the markers, because they were so far apart from each other (5x).

Front

The markers can easily be occluded by the hand which holds the ARPen.

Participants liked the idea of having only a front cube (6x), and the pen was easy to handle (5x). Some mentioned that this pen nearly looks like a real pen (3x). The biggest problem with this pen was that the participants often occluded the markers with their own hand (15x) and had problems when drawing around objects (12x). Some also mentioned that the cube blocks vision on the tip (5x) and that the cube was in their way (4x).

5.9 Discussion

Top cubes are easy to keep within the camera view.

Overall, the ARPens *Top* and *BackTop* were liked the most. They outranked the other pens in nearly every category; for the global ranking *Top* outranked every other pen significantly, except from *BackTop*, which was placed on the second rank. This is no surprise as 20 from our 28 participants stated that it was easy to keep the markers within camera view. The back cube in combination with the top cube is a good addition, but not necessary.

The participants often placed the tip of the pen in the middle of the display, which led to problems with the detection of the back cubes.

Some participants explained that they tried to keep the tip of the pen in the middle of the screen. This is a natural behavior, as this is their point of interaction. Since the top cube is very close to this spot, it became easy to keep track of it. This is also the problem, which the participants had with cubes in the back of the pen. If they placed the tip in the middle of the display, then the markers are close to the edge of the camera view. Therefore, the participants often

accidentally put them outside of the camera view. This led to the participants trying to hold the camera further back. The existence of a front cube unites the interaction point with the location of a marker. Still, this is not necessarily beneficial for the participants, as they often occluded the markers with their hand, which also may lead to frustration when using those pens. This especially affects *Front*, as it has no other cubes to compensate this difficulty. One participant stated that the good visibility of the top cube may come from the fact that it is placed on a different axis than the pen. Therefore, it is easier not to occlude the markers when moving the pen and turning the hand. Overall, top cubes are beneficial and *Top* is the pen to use. Depending on the situation, *BackTop* is a good alternative.

Front cubes are easy to occlude.

Top cubes are beneficial and should be used.

Chapter 6

Summary and Future Work

6.1 Summary and Contributions

In this thesis we created a new ARPen based on the RN4871, as the Red Bear Nano v2 is no longer available. We created a custom PCB for the RN4871, which is powered by regular LiPo batteries and can be connected to three buttons. With the new design and our new hardware, we were able to move every hardware component into the base of the pen, which left the marker cube empty. This includes the PCB, the battery and the buttons in combination with the wiring. We redesigned the ARPen by decreasing the thickness of some walls, while making sure that it remains stable during usage. Having the marker cube empty came with two benefits. First, we were able to distribute the weight along the whole pen instead of concentrating it within the cube, which would have caused the user to actively having to work against it. Second, the empty cube allowed us to shrink it as far as feasible. Furthermore, it was now simple to move the cube to other parts of the pen while keeping the electronic set-up the same across all pens.

We moved all of the hardware to the inside of the pen base, improving the balance of the weight distribution.

We moved the cube to different positions around the ARPen.

We created six additional versions of the ARPen to study different marker placements. The pens we finally used were *Top*, *BackTop*, *TopFront*, *Back BackFront*, *BackFrontSmall* and *Front*. The name indicates the position of the marker cubes for each individual pen. We corrected the tip calculations by Wehnert [2018] and made the calculations for the new positions. With these new calculations, we integrated the pens with their markers into the app.

The participants in our study preferred *Top* and *BackTop*.

In our user study we investigated different marker placements using the different ARPens we created. During the study, the participants used each pen and ranked them against each other. They mostly preferred the pens which had a cube on top. *Top* significantly outranked every other pen, except from *BackTop*. The participants found it specifically easy to keep track of the markers with a smartphone when using these two pens.

6.2 Future Work

In the future we plan to further investigate the tracking of the ARPen. If we find a different way to use markers on the pen itself, we remove the necessity of the marker cube. This would decrease the total size of the ARPen, as the cube is still the biggest component. One possible marker is *RUNE-Tag*, which was introduced by Bergamasco et al. [2011]. These markers are especially interesting, as they perform well dealing with occlusion.

The shape of the ARPen will most likely shift towards having a cube on top. Still we need to evaluate the benefits and drawbacks of a top cube in more detail. Further studies should evaluate use-cases and show benefits and drawbacks of our new design.

Appendix A

RN4871 code

The following code is used to program the RN4871. Every line is explained in Chapter 3.1.5 “Scripting”. To program the RN4871, connect it to a computer as shown in Figure 3.7. After the connection is established, enter every line separately and press *ENTER* on the keyboard after each line. Usually the RN4871 will respond with *AOK*. Some commands restart the RN4871.

```
$$$  
+  
PZ  
SF,1  
$$$  
+  
NA,Z  
SS,00  
WC  
SN,ARPen  
PS,713D0000503E4C75BA943148F18D941E  
PC,713D0002503E4C75BA943148F18D941E,10,07  
SW,0A,09  
SW,0B,0A  
SW,0D,0B  
NA,01,05  
NA,07,1E948DF1483194BA754C3E5000003D71  
NA,08,415250656e  
WW
```

Press *ENTER* after
each line.

You can copy and paste everything from here until you have to press *ESC* at once.

```
@PIO1H
SHW,0072,42333a5550
@PIO1L
SHW,0072,42333a444f574e
@PIO2H
SHW,0072,42323a5550
@PIO2L
SHW,0072,42323a444f574e
@PIO3H
SHW,0072,42313a5550
@PIO3L
SHW,0072,42313a444f574e
```

Press *ESC* on the keyboard.

```
[PRESS ESC]

SR,0040
R,1
```

We explain each line of the code here. For more detailed information we advise to read the [RN4871 User's Guide¹](#), as we are only explaining the necessary details to fulfill the functionality of the ARPen.

\$\$\$

This sequence puts the RN4871 into command mode. Now we are able to apply changes to the chip.

+

This command toggles the local echo. When turned on, everything we type is displayed in our console. Local echo helps us to minimize errors.

PZ

We delete all previous services and characteristics, as a factory reset does not accomplish this.

¹<http://ww1.microchip.com/downloads/en/DeviceDoc/50002466B.pdf> (Accessed: 20.02.2020)

SF, 1

Here we do a factory reset which also restarts the chip. Afterwards we need to put the chip back into command mode (\$\$\$) and activate the local echo (+).

NA, Z

NA, Z clears all advertising data.

SS, 00

We disable all default services, as they are not needed.

WC

We clear any script that is on the chip. This action should be covered by the factory reset, but we use this command to be sure about the current situation.

SN, ARPen

We change the name to *ARPen*. This allows us to select our chip, when connecting with the corresponding app.

PS, 713D0000503E4C75BA943148F18D941E

This command creates a service with an Universally Unique Identifier (UUID), which is used in the ARPen app to subscribe to the characteristic we create with the PC command. The UUID is 713D0000503E4C75BA943148F18D941E.

PC, 713D0002503E4C75BA943148F18D941E, 10, 07

Here we create our private characteristic, which allows the app to be notified of messages that are sent over this channel. We use this characteristic to send the changes in the state of each button on the ARPen to the app. The 10 sets the usage of this characteristic to *notify*. The maximum data size is set to 7 octet. We chose this number to fit our longest string being *B1:DOWN*, which needs 7 characters.

SW, [Pin], [Function]

This command allows us to assign pre-defined functions from the RN4871 to certain pins. The first number defines the pin while the second number represents the function. Table A.1 contains the used numbers. The *Pin Trigger* allows us to detect falling and rising edges on a pin, so we are able to measure button presses and releases. Since there

Assign Pin Triggers
to the correct pins.

are three such functions, we are only able to monitor three buttons. As the ARPen has three buttons, this fulfills our requirements.

Pin Index	Pin	Function Index	Function
0A	P12	09	Pin Trigger 1
0B	P13	0A	Pin Trigger 2
0D	P17	0B	Pin Trigger 3

Table A.1: Pins and functions of the RN4871 with their internal index.

NA

Set the advertising data.

The NA command allows us to make permanent changes to the advertising of the RN4871. With `NA,01,05` we set the advertising flags. `NA,07,1E948DF1483194BA754C3E5000003D71` makes our service visible. If we do not set this value in the given way, smartphones will not receive our notifications. `NA,08,415250656e` sets the short name of the device to *ARPen*, which is 415250656e in hexagonal writing. We need this command, as the name is not shown on iOS devices otherwise.

WW

This command allows us to write a script which the RN4871 will execute.

@PIO[1, 2, 3] [H, L] and SHW, [Handle], [Message]

Detect button presses and notify the subscriber with the corresponding message.

These commands are placed within the script. Each command begins with an event. Once the event triggers, the lines below it get executed. In our case the SHW command will be executed when one of the defined events occurs. SHW writes a hexagonal message into the characteristic that is referred by its handle. The handle for our characteristic is 0072. The according strings for each hexagonal value are visualized in Table A.2. To verify the value of the handle we can use the LS command which lists the defined services with their characteristics.

The events we monitor are the *Pin Trigger* events (@PIO). The number defines which of the three Pin Trigger events we refer to. H detects rising edges, while L detects falling edges. For example @PIO1H is triggered, when there is a rising edge at the pin, that Pin Trigger 1 is assigned to.

Hexagonal	String
42333a5550	B3:UP
42333a444f574e	B3:DOWN
42323a5550	B2:UP
42323a444f574e	B2:DOWN
42313a5550	B1:UP
42313a444f574e	B1:DOWN

Table A.2: The messages that are sent when a button changes its state.

[PRESS ESC]

Pressing ESC on the keyboard exits the scripting mode.

SR, 0040

The chip now automatically runs the script, after being turned on.

R, 1

We restart the chip. Now it is ready for usage.

Appendix B

Study Material

B.1 Questionnaire

The following material contains the questionnaire which was used during the study.

B.1.1 German Questionnaire

Redesigning ARPen: Evaluating Different Marker Positions for Mid-Air Pen Interaction - Fragebogen

ID: _____

Geschlecht: männlich weiblich andere N.A.

Alter: _____

Dominante Hand: rechts links N.A.

VR Erfahrung: gar keine sehr viel

AR Erfahrung: gar keine sehr viel

ARPen Erfahrung: gar keine sehr viel

Mit welchen Geräten/Technologien haben Sie im Bereich VR/AR bereits Erfahrungen gesammelt?

Nach der Studie auszufüllen:

Sortieren Sie die Stifte von 1 (gut) bis 7 (schlecht). Sie dürfen jede Zahl nur einmal vergeben.

Platzierung	
1. (gut)	
2.	
3.	
4.	
5.	
6.	
7. (schlecht)	

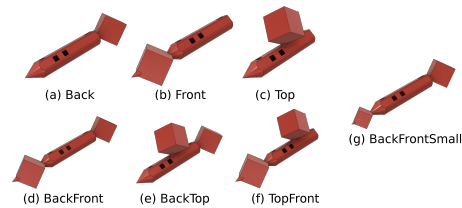

Was gefällt Ihnen an ihrem 1. Platz besser, als an den anderen Stiften?

Was würden Sie an ihrem 1. Platz verbessern?

Sonstige Anmerkungen:

ID:
Stift: Back



Insgesamt bin ich mit dem Stift zufrieden.	Trifft nicht zu	<input type="checkbox"/>	<input type="checkbox"/>	<input type="checkbox"/>	<input type="checkbox"/>	<input type="checkbox"/>	Trifft völlig zu
Es war einfach, den Stift zu benutzen.	Trifft nicht zu	<input type="checkbox"/>	<input type="checkbox"/>	<input type="checkbox"/>	<input type="checkbox"/>	<input type="checkbox"/>	Trifft völlig zu
Ich war in der Lage, die gegebene Aufgabe mit dem Stift effektiv zu erledigen.	Trifft nicht zu	<input type="checkbox"/>	<input type="checkbox"/>	<input type="checkbox"/>	<input type="checkbox"/>	<input type="checkbox"/>	Trifft völlig zu
Es war einfach, den Umgang mit dem Stift zu lernen.	Trifft nicht zu	<input type="checkbox"/>	<input type="checkbox"/>	<input type="checkbox"/>	<input type="checkbox"/>	<input type="checkbox"/>	Trifft völlig zu
Der Umgang mit dem Stift war angenehm für mich.	Trifft nicht zu	<input type="checkbox"/>	<input type="checkbox"/>	<input type="checkbox"/>	<input type="checkbox"/>	<input type="checkbox"/>	Trifft völlig zu

Es folgen Wortpaare, mit welchen Sie den genutzten Stift im Kontext der gestellten Aufgabe subjektiv bewerten können. Denken Sie nicht lange nach. Es gibt keine richtigen und falschen Antworten.

Beispiel:

Dunkel Hell

Diese Aussage bedeutet, dass der getestete Stift eher hell ist

Kompliziert	<input type="checkbox"/>	<input type="checkbox"/>	<input type="checkbox"/>	<input type="checkbox"/>	<input type="checkbox"/>	<input type="checkbox"/>	<input type="checkbox"/>	Einfach
Voraussagbar	<input type="checkbox"/>	<input type="checkbox"/>	<input type="checkbox"/>	<input type="checkbox"/>	<input type="checkbox"/>	<input type="checkbox"/>	<input type="checkbox"/>	Unberechenbar
Handhabbar	<input type="checkbox"/>	<input type="checkbox"/>	<input type="checkbox"/>	<input type="checkbox"/>	<input type="checkbox"/>	<input type="checkbox"/>	<input type="checkbox"/>	Widerspenstig
Umständlich	<input type="checkbox"/>	<input type="checkbox"/>	<input type="checkbox"/>	<input type="checkbox"/>	<input type="checkbox"/>	<input type="checkbox"/>	<input type="checkbox"/>	Direkt
Technisch	<input type="checkbox"/>	<input type="checkbox"/>	<input type="checkbox"/>	<input type="checkbox"/>	<input type="checkbox"/>	<input type="checkbox"/>	<input type="checkbox"/>	Menschlich
Schlecht	<input type="checkbox"/>	<input type="checkbox"/>	<input type="checkbox"/>	<input type="checkbox"/>	<input type="checkbox"/>	<input type="checkbox"/>	<input type="checkbox"/>	Gut
Verwirrend	<input type="checkbox"/>	<input type="checkbox"/>	<input type="checkbox"/>	<input type="checkbox"/>	<input type="checkbox"/>	<input type="checkbox"/>	<input type="checkbox"/>	Übersichtlich
Praktisch	<input type="checkbox"/>	<input type="checkbox"/>	<input type="checkbox"/>	<input type="checkbox"/>	<input type="checkbox"/>	<input type="checkbox"/>	<input type="checkbox"/>	Unpraktisch

Haben Sie während dem Durchführen der gestellten Aufgabe auf das Display, oder daran vorbei geschaut?

Auf das Display Am Display vorbei

Was gefällt Ihnen an diesem Stift?

Was gefällt Ihnen nicht an diesem Stift?

ID:
Stift: BackTop

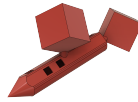

Insgesamt bin ich mit dem Stift zufrieden.	Trifft nicht zu	<input type="checkbox"/>	<input type="checkbox"/>	<input type="checkbox"/>	<input type="checkbox"/>	<input type="checkbox"/>	Trifft völlig zu
Es war einfach, den Stift zu benutzen.	Trifft nicht zu	<input type="checkbox"/>	<input type="checkbox"/>	<input type="checkbox"/>	<input type="checkbox"/>	<input type="checkbox"/>	Trifft völlig zu
Ich war in der Lage, die gegebene Aufgabe mit dem Stift effektiv zu erledigen.	Trifft nicht zu	<input type="checkbox"/>	<input type="checkbox"/>	<input type="checkbox"/>	<input type="checkbox"/>	<input type="checkbox"/>	Trifft völlig zu
Es war einfach, den Umgang mit dem Stift zu lernen.	Trifft nicht zu	<input type="checkbox"/>	<input type="checkbox"/>	<input type="checkbox"/>	<input type="checkbox"/>	<input type="checkbox"/>	Trifft völlig zu
Der Umgang mit dem Stift war angenehm für mich.	Trifft nicht zu	<input type="checkbox"/>	<input type="checkbox"/>	<input type="checkbox"/>	<input type="checkbox"/>	<input type="checkbox"/>	Trifft völlig zu

Es folgen Wortpaare, mit welchen Sie den genutzten Stift im Kontext der gestellten Aufgabe subjektiv bewerten können. Denken Sie nicht lange nach. Es gibt keine richtigen und falschen Antworten.

Beispiel:

Dunkel Hell

Diese Aussage bedeutet, dass der getestete Stift eher hell ist

Kompliziert	<input type="checkbox"/>	<input type="checkbox"/>	<input type="checkbox"/>	<input type="checkbox"/>	<input type="checkbox"/>	<input type="checkbox"/>	<input type="checkbox"/>	Einfach
Voraussagbar	<input type="checkbox"/>	<input type="checkbox"/>	<input type="checkbox"/>	<input type="checkbox"/>	<input type="checkbox"/>	<input type="checkbox"/>	<input type="checkbox"/>	Unberechenbar
Handhabbar	<input type="checkbox"/>	<input type="checkbox"/>	<input type="checkbox"/>	<input type="checkbox"/>	<input type="checkbox"/>	<input type="checkbox"/>	<input type="checkbox"/>	Widerspenstig
Umständlich	<input type="checkbox"/>	<input type="checkbox"/>	<input type="checkbox"/>	<input type="checkbox"/>	<input type="checkbox"/>	<input type="checkbox"/>	<input type="checkbox"/>	Direkt
Technisch	<input type="checkbox"/>	<input type="checkbox"/>	<input type="checkbox"/>	<input type="checkbox"/>	<input type="checkbox"/>	<input type="checkbox"/>	<input type="checkbox"/>	Menschlich
Schlecht	<input type="checkbox"/>	<input type="checkbox"/>	<input type="checkbox"/>	<input type="checkbox"/>	<input type="checkbox"/>	<input type="checkbox"/>	<input type="checkbox"/>	Gut
Verwirrend	<input type="checkbox"/>	<input type="checkbox"/>	<input type="checkbox"/>	<input type="checkbox"/>	<input type="checkbox"/>	<input type="checkbox"/>	<input type="checkbox"/>	Übersichtlich
Praktisch	<input type="checkbox"/>	<input type="checkbox"/>	<input type="checkbox"/>	<input type="checkbox"/>	<input type="checkbox"/>	<input type="checkbox"/>	<input type="checkbox"/>	Unpraktisch

Haben Sie während dem Durchführen der gestellten Aufgabe auf das Display, oder daran vorbei geschaut?

Auf das Display Am Display vorbei

Was gefällt Ihnen an diesem Stift?

Was gefällt Ihnen nicht an diesem Stift?



ID:
Stift: Top

Insgesamt bin ich mit dem Stift zufrieden.	Trifft nicht zu	<input type="checkbox"/>	<input type="checkbox"/>	<input type="checkbox"/>	<input type="checkbox"/>	<input type="checkbox"/>	Trifft völlig zu
Es war einfach, den Stift zu benutzen.	Trifft nicht zu	<input type="checkbox"/>	<input type="checkbox"/>	<input type="checkbox"/>	<input type="checkbox"/>	<input type="checkbox"/>	Trifft völlig zu
Ich war in der Lage, die gegebene Aufgabe mit dem Stift effektiv zu erledigen.	Trifft nicht zu	<input type="checkbox"/>	<input type="checkbox"/>	<input type="checkbox"/>	<input type="checkbox"/>	<input type="checkbox"/>	Trifft völlig zu
Es war einfach, den Umgang mit dem Stift zu lernen.	Trifft nicht zu	<input type="checkbox"/>	<input type="checkbox"/>	<input type="checkbox"/>	<input type="checkbox"/>	<input type="checkbox"/>	Trifft völlig zu
Der Umgang mit dem Stift war angenehm für mich.	Trifft nicht zu	<input type="checkbox"/>	<input type="checkbox"/>	<input type="checkbox"/>	<input type="checkbox"/>	<input type="checkbox"/>	Trifft völlig zu

Es folgen Wortpaare, mit welchen Sie den genutzten Stift im Kontext der gestellten Aufgabe subjektiv bewerten können. Denken Sie nicht lange nach. Es gibt keine richtigen und falschen Antworten.

Beispiel:

Dunkel Hell

Diese Aussage bedeutet, dass der getestete Stift eher hell ist

Kompliziert	<input type="checkbox"/>	<input type="checkbox"/>	<input type="checkbox"/>	<input type="checkbox"/>	<input type="checkbox"/>	<input type="checkbox"/>	<input type="checkbox"/>	Einfach
Voraussagbar	<input type="checkbox"/>	<input type="checkbox"/>	<input type="checkbox"/>	<input type="checkbox"/>	<input type="checkbox"/>	<input type="checkbox"/>	<input type="checkbox"/>	Unberechenbar
Handhabbar	<input type="checkbox"/>	<input type="checkbox"/>	<input type="checkbox"/>	<input type="checkbox"/>	<input type="checkbox"/>	<input type="checkbox"/>	<input type="checkbox"/>	Widerspenstig
Umständlich	<input type="checkbox"/>	<input type="checkbox"/>	<input type="checkbox"/>	<input type="checkbox"/>	<input type="checkbox"/>	<input type="checkbox"/>	<input type="checkbox"/>	Direkt
Technisch	<input type="checkbox"/>	<input type="checkbox"/>	<input type="checkbox"/>	<input type="checkbox"/>	<input type="checkbox"/>	<input type="checkbox"/>	<input type="checkbox"/>	Menschlich
Schlecht	<input type="checkbox"/>	<input type="checkbox"/>	<input type="checkbox"/>	<input type="checkbox"/>	<input type="checkbox"/>	<input type="checkbox"/>	<input type="checkbox"/>	Gut
Verwirrend	<input type="checkbox"/>	<input type="checkbox"/>	<input type="checkbox"/>	<input type="checkbox"/>	<input type="checkbox"/>	<input type="checkbox"/>	<input type="checkbox"/>	Übersichtlich
Praktisch	<input type="checkbox"/>	<input type="checkbox"/>	<input type="checkbox"/>	<input type="checkbox"/>	<input type="checkbox"/>	<input type="checkbox"/>	<input type="checkbox"/>	Unpraktisch

Haben Sie während dem Durchführen der gestellten Aufgabe auf das Display, oder daran vorbei geschaut?

Auf das Display Am Display vorbei

Was gefällt Ihnen an diesem Stift?

Was gefällt Ihnen nicht an diesem Stift?

ID:
Stift: BackFront

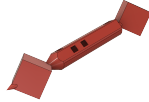

Insgesamt bin ich mit dem Stift zufrieden.	Trifft nicht zu	<input type="checkbox"/>	<input type="checkbox"/>	<input type="checkbox"/>	<input type="checkbox"/>	<input type="checkbox"/>	Trifft völlig zu
Es war einfach, den Stift zu benutzen.	Trifft nicht zu	<input type="checkbox"/>	<input type="checkbox"/>	<input type="checkbox"/>	<input type="checkbox"/>	<input type="checkbox"/>	Trifft völlig zu
Ich war in der Lage, die gegebene Aufgabe mit dem Stift effektiv zu erledigen.	Trifft nicht zu	<input type="checkbox"/>	<input type="checkbox"/>	<input type="checkbox"/>	<input type="checkbox"/>	<input type="checkbox"/>	Trifft völlig zu
Es war einfach, den Umgang mit dem Stift zu lernen.	Trifft nicht zu	<input type="checkbox"/>	<input type="checkbox"/>	<input type="checkbox"/>	<input type="checkbox"/>	<input type="checkbox"/>	Trifft völlig zu
Der Umgang mit dem Stift war angenehm für mich.	Trifft nicht zu	<input type="checkbox"/>	<input type="checkbox"/>	<input type="checkbox"/>	<input type="checkbox"/>	<input type="checkbox"/>	Trifft völlig zu

Es folgen Wortpaare, mit welchen Sie den genutzten Stift im Kontext der gestellten Aufgabe subjektiv bewerten können. Denken Sie nicht lange nach. Es gibt keine richtigen und falschen Antworten.

Beispiel:

Dunkel Hell

Diese Aussage bedeutet, dass der getestete Stift eher hell ist

Kompliziert	<input type="checkbox"/>	<input type="checkbox"/>	<input type="checkbox"/>	<input type="checkbox"/>	<input type="checkbox"/>	<input type="checkbox"/>	Einfach
Voraussagbar	<input type="checkbox"/>	<input type="checkbox"/>	<input type="checkbox"/>	<input type="checkbox"/>	<input type="checkbox"/>	<input type="checkbox"/>	Unberechenbar
Handhabbar	<input type="checkbox"/>	<input type="checkbox"/>	<input type="checkbox"/>	<input type="checkbox"/>	<input type="checkbox"/>	<input type="checkbox"/>	Widerspenstig
Umständlich	<input type="checkbox"/>	<input type="checkbox"/>	<input type="checkbox"/>	<input type="checkbox"/>	<input type="checkbox"/>	<input type="checkbox"/>	Direkt
Technisch	<input type="checkbox"/>	<input type="checkbox"/>	<input type="checkbox"/>	<input type="checkbox"/>	<input type="checkbox"/>	<input type="checkbox"/>	Menschlich
Schlecht	<input type="checkbox"/>	<input type="checkbox"/>	<input type="checkbox"/>	<input type="checkbox"/>	<input type="checkbox"/>	<input type="checkbox"/>	Gut
Verwirrend	<input type="checkbox"/>	<input type="checkbox"/>	<input type="checkbox"/>	<input type="checkbox"/>	<input type="checkbox"/>	<input type="checkbox"/>	Übersichtlich
Praktisch	<input type="checkbox"/>	<input type="checkbox"/>	<input type="checkbox"/>	<input type="checkbox"/>	<input type="checkbox"/>	<input type="checkbox"/>	Unpraktisch

Haben Sie während dem Durchführen der gestellten Aufgabe auf das Display, oder daran vorbei geschaut?

Auf das Display Am Display vorbei

Was gefällt Ihnen an diesem Stift?

Was gefällt Ihnen nicht an diesem Stift?

ID:
Stift: TopFront

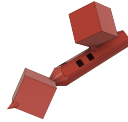

Insgesamt bin ich mit dem Stift zufrieden.	Trifft nicht zu	<input type="checkbox"/>	<input type="checkbox"/>	<input type="checkbox"/>	<input type="checkbox"/>	<input type="checkbox"/>	Trifft völlig zu
Es war einfach, den Stift zu benutzen.	Trifft nicht zu	<input type="checkbox"/>	<input type="checkbox"/>	<input type="checkbox"/>	<input type="checkbox"/>	<input type="checkbox"/>	Trifft völlig zu
Ich war in der Lage, die gegebene Aufgabe mit dem Stift effektiv zu erledigen.	Trifft nicht zu	<input type="checkbox"/>	<input type="checkbox"/>	<input type="checkbox"/>	<input type="checkbox"/>	<input type="checkbox"/>	Trifft völlig zu
Es war einfach, den Umgang mit dem Stift zu lernen.	Trifft nicht zu	<input type="checkbox"/>	<input type="checkbox"/>	<input type="checkbox"/>	<input type="checkbox"/>	<input type="checkbox"/>	Trifft völlig zu
Der Umgang mit dem Stift war angenehm für mich.	Trifft nicht zu	<input type="checkbox"/>	<input type="checkbox"/>	<input type="checkbox"/>	<input type="checkbox"/>	<input type="checkbox"/>	Trifft völlig zu

Es folgen Wortpaare, mit welchen Sie den genutzten Stift im Kontext der gestellten Aufgabe subjektiv bewerten können. Denken Sie nicht lange nach. Es gibt keine richtigen und falschen Antworten.

Beispiel:

Dunkel Hell

Diese Aussage bedeutet, dass der getestete Stift eher hell ist

Kompliziert	<input type="checkbox"/>	<input type="checkbox"/>	<input type="checkbox"/>	<input type="checkbox"/>	<input type="checkbox"/>	<input type="checkbox"/>	<input type="checkbox"/>	Einfach
Voraussagbar	<input type="checkbox"/>	<input type="checkbox"/>	<input type="checkbox"/>	<input type="checkbox"/>	<input type="checkbox"/>	<input type="checkbox"/>	<input type="checkbox"/>	Unberechenbar
Handhabbar	<input type="checkbox"/>	<input type="checkbox"/>	<input type="checkbox"/>	<input type="checkbox"/>	<input type="checkbox"/>	<input type="checkbox"/>	<input type="checkbox"/>	Widerspenstig
Umständlich	<input type="checkbox"/>	<input type="checkbox"/>	<input type="checkbox"/>	<input type="checkbox"/>	<input type="checkbox"/>	<input type="checkbox"/>	<input type="checkbox"/>	Direkt
Technisch	<input type="checkbox"/>	<input type="checkbox"/>	<input type="checkbox"/>	<input type="checkbox"/>	<input type="checkbox"/>	<input type="checkbox"/>	<input type="checkbox"/>	Menschlich
Schlecht	<input type="checkbox"/>	<input type="checkbox"/>	<input type="checkbox"/>	<input type="checkbox"/>	<input type="checkbox"/>	<input type="checkbox"/>	<input type="checkbox"/>	Gut
Verwirrend	<input type="checkbox"/>	<input type="checkbox"/>	<input type="checkbox"/>	<input type="checkbox"/>	<input type="checkbox"/>	<input type="checkbox"/>	<input type="checkbox"/>	Übersichtlich
Praktisch	<input type="checkbox"/>	<input type="checkbox"/>	<input type="checkbox"/>	<input type="checkbox"/>	<input type="checkbox"/>	<input type="checkbox"/>	<input type="checkbox"/>	Unpraktisch

Haben Sie während dem Durchführen der gestellten Aufgabe auf das Display, oder daran vorbei geschaut?

Auf das Display Am Display vorbei

Was gefällt Ihnen an diesem Stift?

Was gefällt Ihnen nicht an diesem Stift?

ID:
Stift: Front

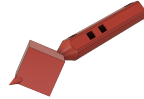

Insgesamt bin ich mit dem Stift zufrieden.	Trifft nicht zu	<input type="checkbox"/>	<input type="checkbox"/>	<input type="checkbox"/>	<input type="checkbox"/>	<input type="checkbox"/>	Trifft völlig zu
Es war einfach, den Stift zu benutzen.	Trifft nicht zu	<input type="checkbox"/>	<input type="checkbox"/>	<input type="checkbox"/>	<input type="checkbox"/>	<input type="checkbox"/>	Trifft völlig zu
Ich war in der Lage, die gegebene Aufgabe mit dem Stift effektiv zu erledigen.	Trifft nicht zu	<input type="checkbox"/>	<input type="checkbox"/>	<input type="checkbox"/>	<input type="checkbox"/>	<input type="checkbox"/>	Trifft völlig zu
Es war einfach, den Umgang mit dem Stift zu lernen.	Trifft nicht zu	<input type="checkbox"/>	<input type="checkbox"/>	<input type="checkbox"/>	<input type="checkbox"/>	<input type="checkbox"/>	Trifft völlig zu
Der Umgang mit dem Stift war angenehm für mich.	Trifft nicht zu	<input type="checkbox"/>	<input type="checkbox"/>	<input type="checkbox"/>	<input type="checkbox"/>	<input type="checkbox"/>	Trifft völlig zu

Es folgen Wortpaare, mit welchen Sie den genutzten Stift im Kontext der gestellten Aufgabe subjektiv bewerten können. Denken Sie nicht lange nach. Es gibt keine richtigen und falschen Antworten.

Beispiel:

Dunkel Hell

Diese Aussage bedeutet, dass der getestete Stift eher hell ist

Kompliziert	<input type="checkbox"/>	<input type="checkbox"/>	<input type="checkbox"/>	<input type="checkbox"/>	<input type="checkbox"/>	<input type="checkbox"/>	<input type="checkbox"/>	Einfach
Voraussagbar	<input type="checkbox"/>	<input type="checkbox"/>	<input type="checkbox"/>	<input type="checkbox"/>	<input type="checkbox"/>	<input type="checkbox"/>	<input type="checkbox"/>	Unberechenbar
Handhabbar	<input type="checkbox"/>	<input type="checkbox"/>	<input type="checkbox"/>	<input type="checkbox"/>	<input type="checkbox"/>	<input type="checkbox"/>	<input type="checkbox"/>	Widerspenstig
Umständlich	<input type="checkbox"/>	<input type="checkbox"/>	<input type="checkbox"/>	<input type="checkbox"/>	<input type="checkbox"/>	<input type="checkbox"/>	<input type="checkbox"/>	Direkt
Technisch	<input type="checkbox"/>	<input type="checkbox"/>	<input type="checkbox"/>	<input type="checkbox"/>	<input type="checkbox"/>	<input type="checkbox"/>	<input type="checkbox"/>	Menschlich
Schlecht	<input type="checkbox"/>	<input type="checkbox"/>	<input type="checkbox"/>	<input type="checkbox"/>	<input type="checkbox"/>	<input type="checkbox"/>	<input type="checkbox"/>	Gut
Verwirrend	<input type="checkbox"/>	<input type="checkbox"/>	<input type="checkbox"/>	<input type="checkbox"/>	<input type="checkbox"/>	<input type="checkbox"/>	<input type="checkbox"/>	Übersichtlich
Praktisch	<input type="checkbox"/>	<input type="checkbox"/>	<input type="checkbox"/>	<input type="checkbox"/>	<input type="checkbox"/>	<input type="checkbox"/>	<input type="checkbox"/>	Unpraktisch

Haben Sie während dem Durchführen der gestellten Aufgabe auf das Display, oder daran vorbei geschaut?

Auf das Display Am Display vorbei

Was gefällt Ihnen an diesem Stift?

Was gefällt Ihnen nicht an diesem Stift?

ID:

Stift: BackFrontSmall

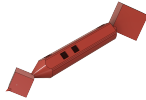

Insgesamt bin ich mit dem Stift zufrieden.	Trifft nicht zu	<input type="checkbox"/>	<input type="checkbox"/>	<input type="checkbox"/>	<input type="checkbox"/>	<input type="checkbox"/>	Trifft völlig zu
Es war einfach, den Stift zu benutzen.	Trifft nicht zu	<input type="checkbox"/>	<input type="checkbox"/>	<input type="checkbox"/>	<input type="checkbox"/>	<input type="checkbox"/>	Trifft völlig zu
Ich war in der Lage, die gegebene Aufgabe mit dem Stift effektiv zu erledigen.	Trifft nicht zu	<input type="checkbox"/>	<input type="checkbox"/>	<input type="checkbox"/>	<input type="checkbox"/>	<input type="checkbox"/>	Trifft völlig zu
Es war einfach, den Umgang mit dem Stift zu lernen.	Trifft nicht zu	<input type="checkbox"/>	<input type="checkbox"/>	<input type="checkbox"/>	<input type="checkbox"/>	<input type="checkbox"/>	Trifft völlig zu
Der Umgang mit dem Stift war angenehm für mich.	Trifft nicht zu	<input type="checkbox"/>	<input type="checkbox"/>	<input type="checkbox"/>	<input type="checkbox"/>	<input type="checkbox"/>	Trifft völlig zu

Es folgen Wortpaare, mit welchen Sie den genutzten Stift im Kontext der gestellten Aufgabe subjektiv bewerten können. Denken Sie nicht lange nach. Es gibt keine richtigen und falschen Antworten.

Beispiel:

Dunkel Hell

Diese Aussage bedeutet, dass der getestete Stift eher hell ist

Kompliziert	<input type="checkbox"/>	<input type="checkbox"/>	<input type="checkbox"/>	<input type="checkbox"/>	<input type="checkbox"/>	<input type="checkbox"/>	<input type="checkbox"/>	Einfach
Voraussagbar	<input type="checkbox"/>	<input type="checkbox"/>	<input type="checkbox"/>	<input type="checkbox"/>	<input type="checkbox"/>	<input type="checkbox"/>	<input type="checkbox"/>	Unberechenbar
Handhabbar	<input type="checkbox"/>	<input type="checkbox"/>	<input type="checkbox"/>	<input type="checkbox"/>	<input type="checkbox"/>	<input type="checkbox"/>	<input type="checkbox"/>	Widerspenstig
Umständlich	<input type="checkbox"/>	<input type="checkbox"/>	<input type="checkbox"/>	<input type="checkbox"/>	<input type="checkbox"/>	<input type="checkbox"/>	<input type="checkbox"/>	Direkt
Technisch	<input type="checkbox"/>	<input type="checkbox"/>	<input type="checkbox"/>	<input type="checkbox"/>	<input type="checkbox"/>	<input type="checkbox"/>	<input type="checkbox"/>	Menschlich
Schlecht	<input type="checkbox"/>	<input type="checkbox"/>	<input type="checkbox"/>	<input type="checkbox"/>	<input type="checkbox"/>	<input type="checkbox"/>	<input type="checkbox"/>	Gut
Verwirrend	<input type="checkbox"/>	<input type="checkbox"/>	<input type="checkbox"/>	<input type="checkbox"/>	<input type="checkbox"/>	<input type="checkbox"/>	<input type="checkbox"/>	Übersichtlich
Praktisch	<input type="checkbox"/>	<input type="checkbox"/>	<input type="checkbox"/>	<input type="checkbox"/>	<input type="checkbox"/>	<input type="checkbox"/>	<input type="checkbox"/>	Unpraktisch

Haben Sie während dem Durchführen der gestellten Aufgabe auf das Display, oder daran vorbei geschaut?

Auf das Display Am Display vorbei

Was gefällt Ihnen an diesem Stift?

Was gefällt Ihnen nicht an diesem Stift?

B.1.2 English Questionnaire

Redesigning ARPen: Evaluating Different Marker Positions for Mid-Air Pen Interaction - Questionnaire

ID: _____

Gender: male female other N.A.

Age: _____

Dominant Hand: right left N.A.

VR Experience: none very much

AR Experience: none very much

ARPen Experience: none very much

Which devices/technologies have you already used in the field of VR/AR?

Fill out after the study:

Rank the pens from 1 (good) to 7 (bad). Each rank must only be used once.

Ranking	
1. (good)	
2.	
3.	
4.	
5.	
6.	
7. (bad)	

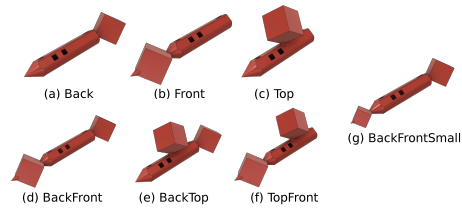

What do you like better about your first rank compared to the other pens?

How would you improve your first rank?

Additional comments:

ID:
Pen: Back



Overall, I am satisfied with this pen.	Strongly disagree	<input type="checkbox"/>	<input type="checkbox"/>	<input type="checkbox"/>	<input type="checkbox"/>	<input type="checkbox"/>	Strongly agree
It was simple to use this pen.	Strongly disagree	<input type="checkbox"/>	<input type="checkbox"/>	<input type="checkbox"/>	<input type="checkbox"/>	<input type="checkbox"/>	Strongly agree
I could effectively complete the task using this pen.	Strongly disagree	<input type="checkbox"/>	<input type="checkbox"/>	<input type="checkbox"/>	<input type="checkbox"/>	<input type="checkbox"/>	Strongly agree
It was easy to learn to use this pen	Strongly disagree	<input type="checkbox"/>	<input type="checkbox"/>	<input type="checkbox"/>	<input type="checkbox"/>	<input type="checkbox"/>	Strongly agree
I felt comfortable using this pen	Strongly disagree	<input type="checkbox"/>	<input type="checkbox"/>	<input type="checkbox"/>	<input type="checkbox"/>	<input type="checkbox"/>	Strongly agree

In the following table there are word pairs, which you will use to subjectively rate the used pen in the context of the given task. Do not think too long about the answers. There is no right or wrong.

Example:

Dark Bright
This states that the used pen is rather bright

Complicated	<input type="checkbox"/>	<input type="checkbox"/>	<input type="checkbox"/>	<input type="checkbox"/>	<input type="checkbox"/>	<input type="checkbox"/>	<input type="checkbox"/>	Simple
Predictable	<input type="checkbox"/>	<input type="checkbox"/>	<input type="checkbox"/>	<input type="checkbox"/>	<input type="checkbox"/>	<input type="checkbox"/>	<input type="checkbox"/>	Unpredictable
Manageable	<input type="checkbox"/>	<input type="checkbox"/>	<input type="checkbox"/>	<input type="checkbox"/>	<input type="checkbox"/>	<input type="checkbox"/>	<input type="checkbox"/>	Unruly
Cumbersome	<input type="checkbox"/>	<input type="checkbox"/>	<input type="checkbox"/>	<input type="checkbox"/>	<input type="checkbox"/>	<input type="checkbox"/>	<input type="checkbox"/>	Direct
Technical	<input type="checkbox"/>	<input type="checkbox"/>	<input type="checkbox"/>	<input type="checkbox"/>	<input type="checkbox"/>	<input type="checkbox"/>	<input type="checkbox"/>	Human
Bad	<input type="checkbox"/>	<input type="checkbox"/>	<input type="checkbox"/>	<input type="checkbox"/>	<input type="checkbox"/>	<input type="checkbox"/>	<input type="checkbox"/>	Good
Confusing	<input type="checkbox"/>	<input type="checkbox"/>	<input type="checkbox"/>	<input type="checkbox"/>	<input type="checkbox"/>	<input type="checkbox"/>	<input type="checkbox"/>	Clear
Practical	<input type="checkbox"/>	<input type="checkbox"/>	<input type="checkbox"/>	<input type="checkbox"/>	<input type="checkbox"/>	<input type="checkbox"/>	<input type="checkbox"/>	Impractical

Did you look on the display or past it during the given task?

On the Display Past the Display

What do you like about this pen?

What do you not like about this pen?

ID:
Pen: BackTop

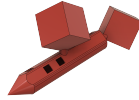

Overall, I am satisfied with this pen.	Strongly disagree	<input type="checkbox"/>	<input type="checkbox"/>	<input type="checkbox"/>	<input type="checkbox"/>	<input type="checkbox"/>	Strongly agree
It was simple to use this pen.	Strongly disagree	<input type="checkbox"/>	<input type="checkbox"/>	<input type="checkbox"/>	<input type="checkbox"/>	<input type="checkbox"/>	Strongly agree
I could effectively complete the task using this pen.	Strongly disagree	<input type="checkbox"/>	<input type="checkbox"/>	<input type="checkbox"/>	<input type="checkbox"/>	<input type="checkbox"/>	Strongly agree
It was easy to learn to use this pen	Strongly disagree	<input type="checkbox"/>	<input type="checkbox"/>	<input type="checkbox"/>	<input type="checkbox"/>	<input type="checkbox"/>	Strongly agree
I felt comfortable using this pen	Strongly disagree	<input type="checkbox"/>	<input type="checkbox"/>	<input type="checkbox"/>	<input type="checkbox"/>	<input type="checkbox"/>	Strongly agree

In the following table there are word pairs, which you will use to subjectively rate the used pen in the context of the given task. Do not think too long about the answers. There is no right or wrong.

Example:

Dark Bright
This states that the used pen is rather bright

Complicated	<input type="checkbox"/>	<input type="checkbox"/>	<input type="checkbox"/>	<input type="checkbox"/>	<input type="checkbox"/>	<input type="checkbox"/>	Simple
Predictable	<input type="checkbox"/>	<input type="checkbox"/>	<input type="checkbox"/>	<input type="checkbox"/>	<input type="checkbox"/>	<input type="checkbox"/>	Unpredictable
Manageable	<input type="checkbox"/>	<input type="checkbox"/>	<input type="checkbox"/>	<input type="checkbox"/>	<input type="checkbox"/>	<input type="checkbox"/>	Unruly
Cumbersome	<input type="checkbox"/>	<input type="checkbox"/>	<input type="checkbox"/>	<input type="checkbox"/>	<input type="checkbox"/>	<input type="checkbox"/>	Direct
Technical	<input type="checkbox"/>	<input type="checkbox"/>	<input type="checkbox"/>	<input type="checkbox"/>	<input type="checkbox"/>	<input type="checkbox"/>	Human
Bad	<input type="checkbox"/>	<input type="checkbox"/>	<input type="checkbox"/>	<input type="checkbox"/>	<input type="checkbox"/>	<input type="checkbox"/>	Good
Confusing	<input type="checkbox"/>	<input type="checkbox"/>	<input type="checkbox"/>	<input type="checkbox"/>	<input type="checkbox"/>	<input type="checkbox"/>	Clear
Practical	<input type="checkbox"/>	<input type="checkbox"/>	<input type="checkbox"/>	<input type="checkbox"/>	<input type="checkbox"/>	<input type="checkbox"/>	Impractical

Did you look on the display or past it during the given task?

On the Display Past the Display

What do you like about this pen?

What do you not like about this pen?

ID:
Pen: Top



Overall, I am satisfied with this pen.	Strongly disagree	<input type="checkbox"/>	<input type="checkbox"/>	<input type="checkbox"/>	<input type="checkbox"/>	<input type="checkbox"/>	Strongly agree
It was simple to use this pen.	Strongly disagree	<input type="checkbox"/>	<input type="checkbox"/>	<input type="checkbox"/>	<input type="checkbox"/>	<input type="checkbox"/>	Strongly agree
I could effectively complete the task using this pen.	Strongly disagree	<input type="checkbox"/>	<input type="checkbox"/>	<input type="checkbox"/>	<input type="checkbox"/>	<input type="checkbox"/>	Strongly agree
It was easy to learn to use this pen	Strongly disagree	<input type="checkbox"/>	<input type="checkbox"/>	<input type="checkbox"/>	<input type="checkbox"/>	<input type="checkbox"/>	Strongly agree
I felt comfortable using this pen	Strongly disagree	<input type="checkbox"/>	<input type="checkbox"/>	<input type="checkbox"/>	<input type="checkbox"/>	<input type="checkbox"/>	Strongly agree

In the following table there are word pairs, which you will use to subjectively rate the used pen in the context of the given task. Do not think too long about the answers. There is no right or wrong.

Example:

Dark Bright
This states that the used pen is rather bright

Complicated	<input type="checkbox"/>	<input type="checkbox"/>	<input type="checkbox"/>	<input type="checkbox"/>	<input type="checkbox"/>	<input type="checkbox"/>	<input type="checkbox"/>	Simple
Predictable	<input type="checkbox"/>	<input type="checkbox"/>	<input type="checkbox"/>	<input type="checkbox"/>	<input type="checkbox"/>	<input type="checkbox"/>	<input type="checkbox"/>	Unpredictable
Manageable	<input type="checkbox"/>	<input type="checkbox"/>	<input type="checkbox"/>	<input type="checkbox"/>	<input type="checkbox"/>	<input type="checkbox"/>	<input type="checkbox"/>	Unruly
Cumbersome	<input type="checkbox"/>	<input type="checkbox"/>	<input type="checkbox"/>	<input type="checkbox"/>	<input type="checkbox"/>	<input type="checkbox"/>	<input type="checkbox"/>	Direct
Technical	<input type="checkbox"/>	<input type="checkbox"/>	<input type="checkbox"/>	<input type="checkbox"/>	<input type="checkbox"/>	<input type="checkbox"/>	<input type="checkbox"/>	Human
Bad	<input type="checkbox"/>	<input type="checkbox"/>	<input type="checkbox"/>	<input type="checkbox"/>	<input type="checkbox"/>	<input type="checkbox"/>	<input type="checkbox"/>	Good
Confusing	<input type="checkbox"/>	<input type="checkbox"/>	<input type="checkbox"/>	<input type="checkbox"/>	<input type="checkbox"/>	<input type="checkbox"/>	<input type="checkbox"/>	Clear
Practical	<input type="checkbox"/>	<input type="checkbox"/>	<input type="checkbox"/>	<input type="checkbox"/>	<input type="checkbox"/>	<input type="checkbox"/>	<input type="checkbox"/>	Impractical

Did you look on the display or past it during the given task?

On the Display Past the Display

What do you like about this pen?

What do you not like about this pen?

ID:
Pen: BackFront

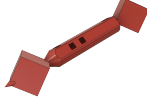

Overall, I am satisfied with this pen.	Strongly disagree	<input type="checkbox"/>	<input type="checkbox"/>	<input type="checkbox"/>	<input type="checkbox"/>	<input type="checkbox"/>	Strongly agree
It was simple to use this pen.	Strongly disagree	<input type="checkbox"/>	<input type="checkbox"/>	<input type="checkbox"/>	<input type="checkbox"/>	<input type="checkbox"/>	Strongly agree
I could effectively complete the task using this pen.	Strongly disagree	<input type="checkbox"/>	<input type="checkbox"/>	<input type="checkbox"/>	<input type="checkbox"/>	<input type="checkbox"/>	Strongly agree
It was easy to learn to use this pen	Strongly disagree	<input type="checkbox"/>	<input type="checkbox"/>	<input type="checkbox"/>	<input type="checkbox"/>	<input type="checkbox"/>	Strongly agree
I felt comfortable using this pen	Strongly disagree	<input type="checkbox"/>	<input type="checkbox"/>	<input type="checkbox"/>	<input type="checkbox"/>	<input type="checkbox"/>	Strongly agree

In the following table there are word pairs, which you will use to subjectively rate the used pen in the context of the given task. Do not think too long about the answers. There is no right or wrong.

Example:

Dark Bright
This states that the used pen is rather bright

Complicated	<input type="checkbox"/>	<input type="checkbox"/>	<input type="checkbox"/>	<input type="checkbox"/>	<input type="checkbox"/>	<input type="checkbox"/>	Simple
Predictable	<input type="checkbox"/>	<input type="checkbox"/>	<input type="checkbox"/>	<input type="checkbox"/>	<input type="checkbox"/>	<input type="checkbox"/>	Unpredictable
Manageable	<input type="checkbox"/>	<input type="checkbox"/>	<input type="checkbox"/>	<input type="checkbox"/>	<input type="checkbox"/>	<input type="checkbox"/>	Unruly
Cumbersome	<input type="checkbox"/>	<input type="checkbox"/>	<input type="checkbox"/>	<input type="checkbox"/>	<input type="checkbox"/>	<input type="checkbox"/>	Direct
Technical	<input type="checkbox"/>	<input type="checkbox"/>	<input type="checkbox"/>	<input type="checkbox"/>	<input type="checkbox"/>	<input type="checkbox"/>	Human
Bad	<input type="checkbox"/>	<input type="checkbox"/>	<input type="checkbox"/>	<input type="checkbox"/>	<input type="checkbox"/>	<input type="checkbox"/>	Good
Confusing	<input type="checkbox"/>	<input type="checkbox"/>	<input type="checkbox"/>	<input type="checkbox"/>	<input type="checkbox"/>	<input type="checkbox"/>	Clear
Practical	<input type="checkbox"/>	<input type="checkbox"/>	<input type="checkbox"/>	<input type="checkbox"/>	<input type="checkbox"/>	<input type="checkbox"/>	Impractical

Did you look on the display or past it during the given task?

On the Display Past the Display

What do you like about this pen?

What do you not like about this pen?

ID:
Pen: TopFront

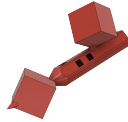

Overall, I am satisfied with this pen.	Strongly disagree	<input type="checkbox"/>	<input type="checkbox"/>	<input type="checkbox"/>	<input type="checkbox"/>	<input type="checkbox"/>	Strongly agree
It was simple to use this pen.	Strongly disagree	<input type="checkbox"/>	<input type="checkbox"/>	<input type="checkbox"/>	<input type="checkbox"/>	<input type="checkbox"/>	Strongly agree
I could effectively complete the task using this pen.	Strongly disagree	<input type="checkbox"/>	<input type="checkbox"/>	<input type="checkbox"/>	<input type="checkbox"/>	<input type="checkbox"/>	Strongly agree
It was easy to learn to use this pen	Strongly disagree	<input type="checkbox"/>	<input type="checkbox"/>	<input type="checkbox"/>	<input type="checkbox"/>	<input type="checkbox"/>	Strongly agree
I felt comfortable using this pen	Strongly disagree	<input type="checkbox"/>	<input type="checkbox"/>	<input type="checkbox"/>	<input type="checkbox"/>	<input type="checkbox"/>	Strongly agree

In the following table there are word pairs, which you will use to subjectively rate the used pen in the context of the given task. Do not think too long about the answers. There is no right or wrong.

Example:

Dark Bright
This states that the used pen is rather bright

Complicated	<input type="checkbox"/>	<input type="checkbox"/>	<input type="checkbox"/>	<input type="checkbox"/>	<input type="checkbox"/>	<input type="checkbox"/>	Simple
Predictable	<input type="checkbox"/>	<input type="checkbox"/>	<input type="checkbox"/>	<input type="checkbox"/>	<input type="checkbox"/>	<input type="checkbox"/>	Unpredictable
Manageable	<input type="checkbox"/>	<input type="checkbox"/>	<input type="checkbox"/>	<input type="checkbox"/>	<input type="checkbox"/>	<input type="checkbox"/>	Unruly
Cumbersome	<input type="checkbox"/>	<input type="checkbox"/>	<input type="checkbox"/>	<input type="checkbox"/>	<input type="checkbox"/>	<input type="checkbox"/>	Direct
Technical	<input type="checkbox"/>	<input type="checkbox"/>	<input type="checkbox"/>	<input type="checkbox"/>	<input type="checkbox"/>	<input type="checkbox"/>	Human
Bad	<input type="checkbox"/>	<input type="checkbox"/>	<input type="checkbox"/>	<input type="checkbox"/>	<input type="checkbox"/>	<input type="checkbox"/>	Good
Confusing	<input type="checkbox"/>	<input type="checkbox"/>	<input type="checkbox"/>	<input type="checkbox"/>	<input type="checkbox"/>	<input type="checkbox"/>	Clear
Practical	<input type="checkbox"/>	<input type="checkbox"/>	<input type="checkbox"/>	<input type="checkbox"/>	<input type="checkbox"/>	<input type="checkbox"/>	Impractical

Did you look on the display or past it during the given task?

On the Display Past the Display

What do you like about this pen?

What do you not like about this pen?

ID:
Pen: Front

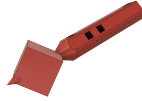

Overall, I am satisfied with this pen.	Strongly disagree	<input type="checkbox"/>	<input type="checkbox"/>	<input type="checkbox"/>	<input type="checkbox"/>	<input type="checkbox"/>	Strongly agree
It was simple to use this pen.	Strongly disagree	<input type="checkbox"/>	<input type="checkbox"/>	<input type="checkbox"/>	<input type="checkbox"/>	<input type="checkbox"/>	Strongly agree
I could effectively complete the task using this pen.	Strongly disagree	<input type="checkbox"/>	<input type="checkbox"/>	<input type="checkbox"/>	<input type="checkbox"/>	<input type="checkbox"/>	Strongly agree
It was easy to learn to use this pen	Strongly disagree	<input type="checkbox"/>	<input type="checkbox"/>	<input type="checkbox"/>	<input type="checkbox"/>	<input type="checkbox"/>	Strongly agree
I felt comfortable using this pen	Strongly disagree	<input type="checkbox"/>	<input type="checkbox"/>	<input type="checkbox"/>	<input type="checkbox"/>	<input type="checkbox"/>	Strongly agree

In the following table there are word pairs, which you will use to subjectively rate the used pen in the context of the given task. Do not think too long about the answers. There is no right or wrong.

Example:

Dark Bright
This states that the used pen is rather bright

Complicated	<input type="checkbox"/>	<input type="checkbox"/>	<input type="checkbox"/>	<input type="checkbox"/>	<input type="checkbox"/>	<input type="checkbox"/>	Simple
Predictable	<input type="checkbox"/>	<input type="checkbox"/>	<input type="checkbox"/>	<input type="checkbox"/>	<input type="checkbox"/>	<input type="checkbox"/>	Unpredictable
Manageable	<input type="checkbox"/>	<input type="checkbox"/>	<input type="checkbox"/>	<input type="checkbox"/>	<input type="checkbox"/>	<input type="checkbox"/>	Unruly
Cumbersome	<input type="checkbox"/>	<input type="checkbox"/>	<input type="checkbox"/>	<input type="checkbox"/>	<input type="checkbox"/>	<input type="checkbox"/>	Direct
Technical	<input type="checkbox"/>	<input type="checkbox"/>	<input type="checkbox"/>	<input type="checkbox"/>	<input type="checkbox"/>	<input type="checkbox"/>	Human
Bad	<input type="checkbox"/>	<input type="checkbox"/>	<input type="checkbox"/>	<input type="checkbox"/>	<input type="checkbox"/>	<input type="checkbox"/>	Good
Confusing	<input type="checkbox"/>	<input type="checkbox"/>	<input type="checkbox"/>	<input type="checkbox"/>	<input type="checkbox"/>	<input type="checkbox"/>	Clear
Practical	<input type="checkbox"/>	<input type="checkbox"/>	<input type="checkbox"/>	<input type="checkbox"/>	<input type="checkbox"/>	<input type="checkbox"/>	Impractical

Did you look on the display or past it during the given task?

On the Display Past the Display

What do you like about this pen?

What do you not like about this pen?

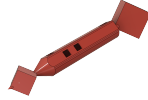

ID:
Pen: BackFrontSmall

Overall, I am satisfied with this pen.	Strongly disagree	<input type="checkbox"/>	<input type="checkbox"/>	<input type="checkbox"/>	<input type="checkbox"/>	<input type="checkbox"/>	Strongly agree
It was simple to use this pen.	Strongly disagree	<input type="checkbox"/>	<input type="checkbox"/>	<input type="checkbox"/>	<input type="checkbox"/>	<input type="checkbox"/>	Strongly agree
I could effectively complete the task using this pen.	Strongly disagree	<input type="checkbox"/>	<input type="checkbox"/>	<input type="checkbox"/>	<input type="checkbox"/>	<input type="checkbox"/>	Strongly agree
It was easy to learn to use this pen	Strongly disagree	<input type="checkbox"/>	<input type="checkbox"/>	<input type="checkbox"/>	<input type="checkbox"/>	<input type="checkbox"/>	Strongly agree
I felt comfortable using this pen	Strongly disagree	<input type="checkbox"/>	<input type="checkbox"/>	<input type="checkbox"/>	<input type="checkbox"/>	<input type="checkbox"/>	Strongly agree

In the following table there are word pairs, which you will use to subjectively rate the used pen in the context of the given task. Do not think too long about the answers. There is no right or wrong.

Example:

Dark Bright
This states that the used pen is rather bright

Complicated	<input type="checkbox"/>	<input type="checkbox"/>	<input type="checkbox"/>	<input type="checkbox"/>	<input type="checkbox"/>	<input type="checkbox"/>	Simple
Predictable	<input type="checkbox"/>	<input type="checkbox"/>	<input type="checkbox"/>	<input type="checkbox"/>	<input type="checkbox"/>	<input type="checkbox"/>	Unpredictable
Manageable	<input type="checkbox"/>	<input type="checkbox"/>	<input type="checkbox"/>	<input type="checkbox"/>	<input type="checkbox"/>	<input type="checkbox"/>	Unruly
Cumbersome	<input type="checkbox"/>	<input type="checkbox"/>	<input type="checkbox"/>	<input type="checkbox"/>	<input type="checkbox"/>	<input type="checkbox"/>	Direct
Technical	<input type="checkbox"/>	<input type="checkbox"/>	<input type="checkbox"/>	<input type="checkbox"/>	<input type="checkbox"/>	<input type="checkbox"/>	Human
Bad	<input type="checkbox"/>	<input type="checkbox"/>	<input type="checkbox"/>	<input type="checkbox"/>	<input type="checkbox"/>	<input type="checkbox"/>	Good
Confusing	<input type="checkbox"/>	<input type="checkbox"/>	<input type="checkbox"/>	<input type="checkbox"/>	<input type="checkbox"/>	<input type="checkbox"/>	Clear
Practical	<input type="checkbox"/>	<input type="checkbox"/>	<input type="checkbox"/>	<input type="checkbox"/>	<input type="checkbox"/>	<input type="checkbox"/>	Impractical

Did you look on the display or past it during the given task?

On the Display Past the Display

What do you like about this pen?

What do you not like about this pen?

B.2 Results

The following graphics contain all individual graphs for the results of the *Post-Study System Usability Questionnaire* and the *AttrakDiff 2*.

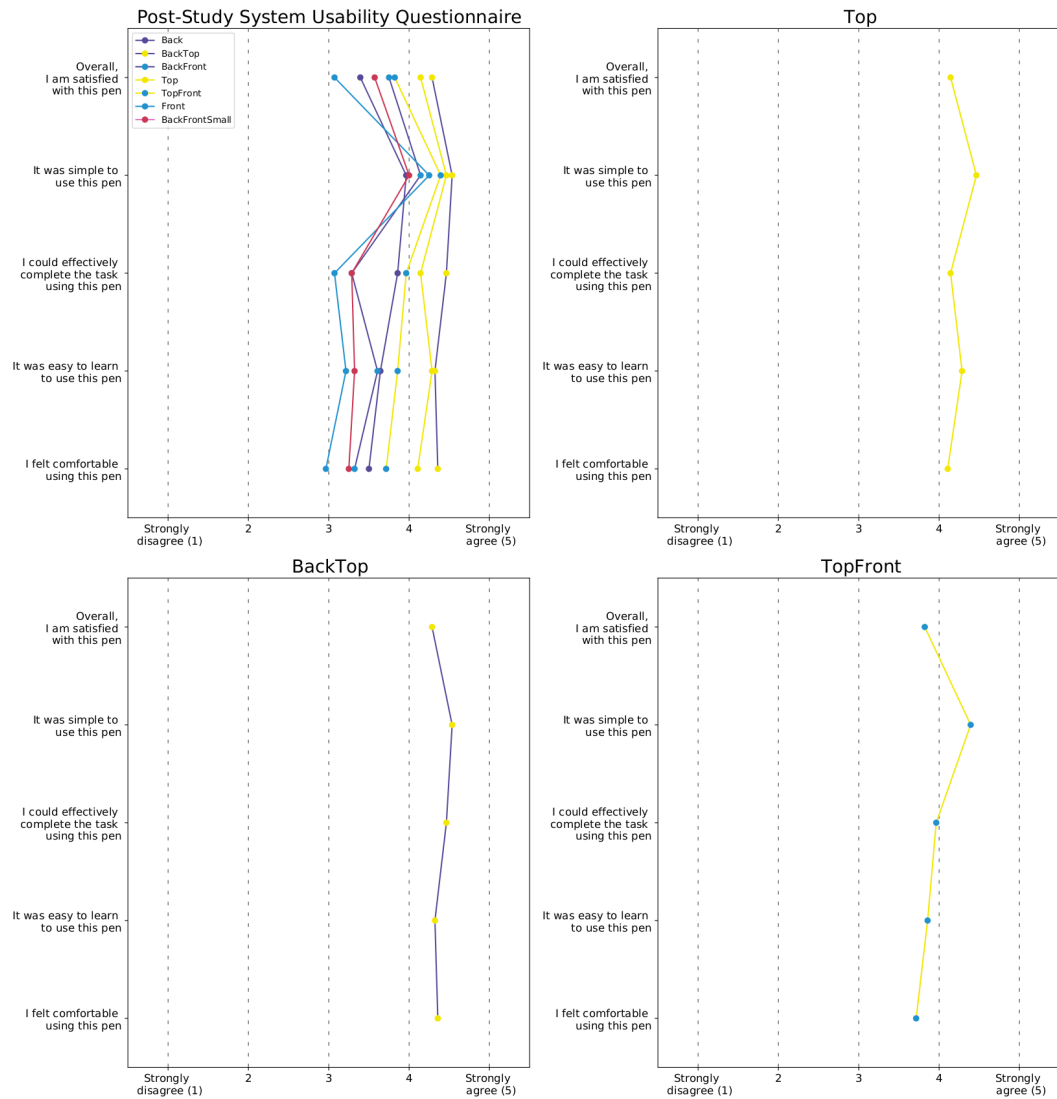

Figure B.1: Post-Study System Usability Questionnaire for *All Pens*, *Top*, *BackTop* and *TopFront*.

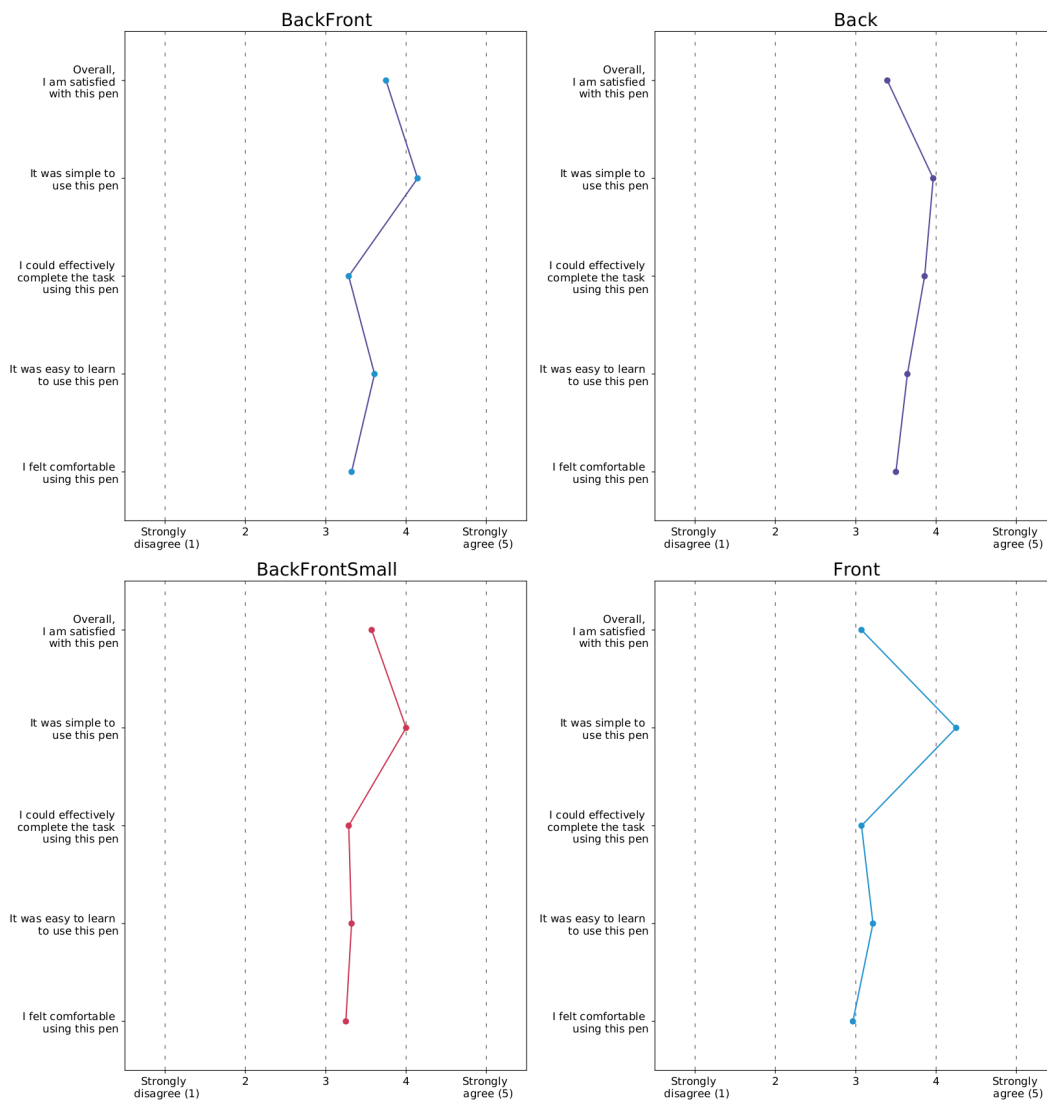

Figure B.2: Post-Study System Usability Questionnaire for *BackFront*, *Back*, *Back-FrontSmall* and *Front*.

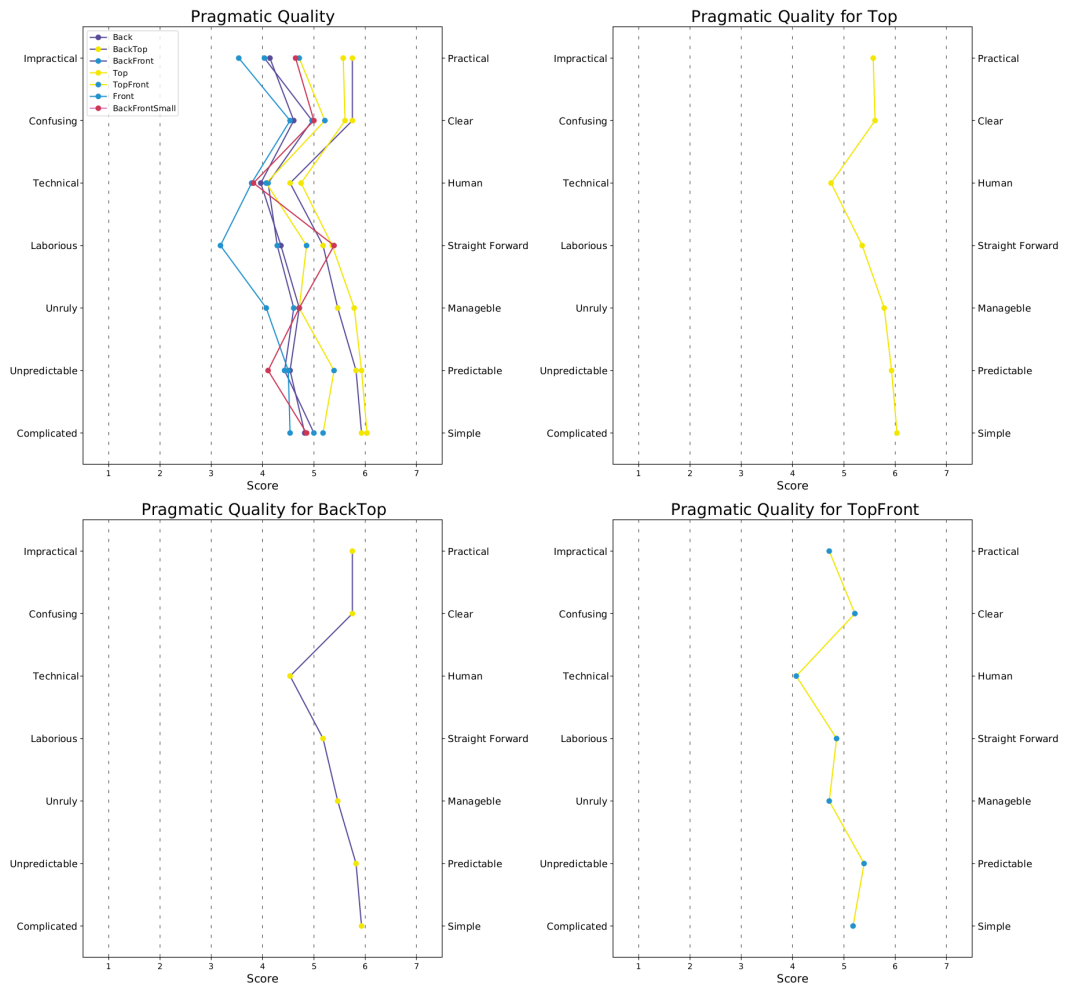

Figure B.3: Pragmatic Quality using the AttrakDiff 2 Questionnaire for *All Pens*, *Top*, *BackTop* and *TopFront*.

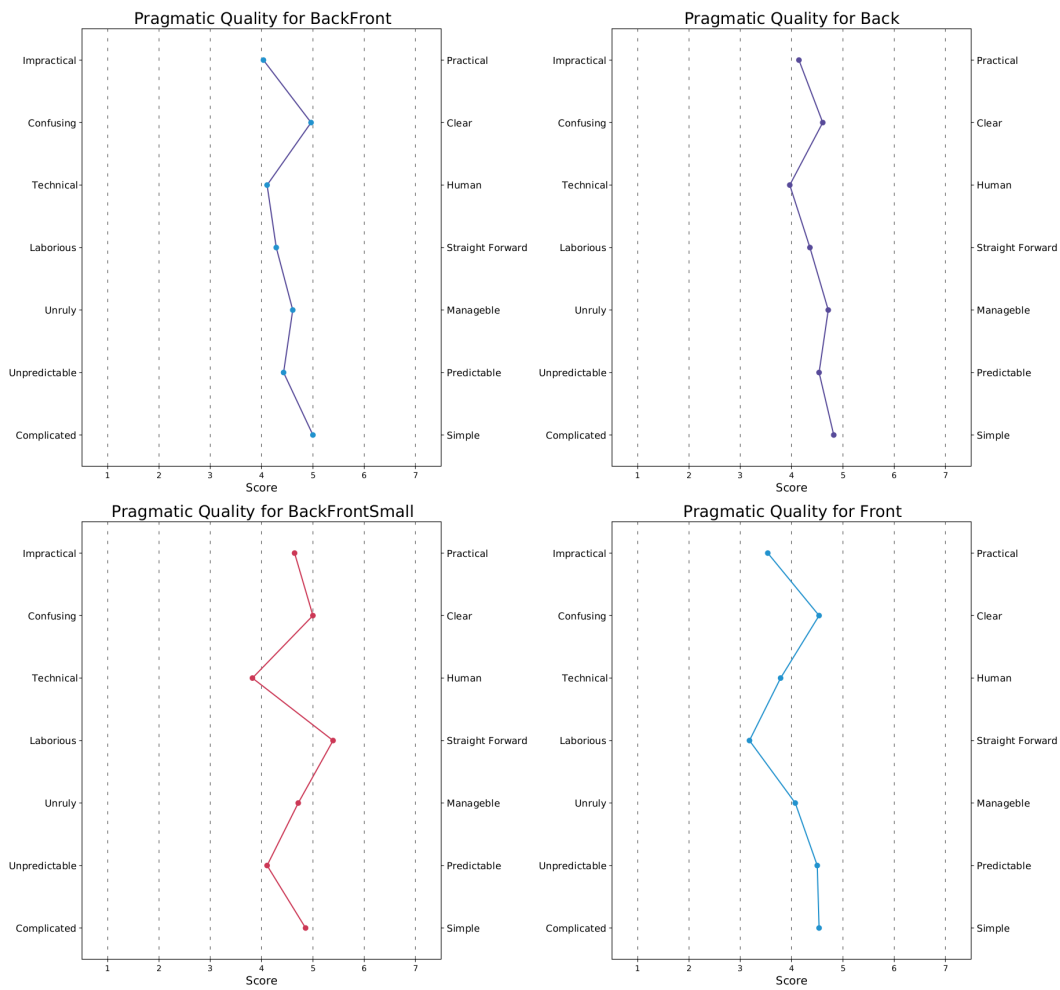

Figure B.4: Pragmatic Quality using the AttrakDiff 2 Questionnaire for *BackFront*, *Back*, *BackFrontSmall* and *Front*.

Bibliography

- Abrar Omar Alkhamisi, Saudi Arabia, Muhammad Mostafa Monowar, et al. Rise of augmented reality: Current and future application areas. *International journal of internet and distributed systems*, 1(04):25, 2013.
- Ajay Apte and Takayuki Dan Kimura. A comparison study of the pen and the mouse in editing graphic diagrams. In *Proceedings 1993 IEEE Symposium on Visual Languages*, pages 352–357. IEEE, 1993.
- Rahul Arora, Rubaiat Habib Kazi, Tovi Grossman, George Fitzmaurice, and Karan Singh. Symbiosissketch: Combining 2d & 3d sketching for designing detailed 3d objects in situ. In *Proceedings of the 2018 CHI Conference on Human Factors in Computing Systems*, pages 1–15, 2018.
- Ronald Azuma, Yohan Baillot, Reinhold Behringer, Steven Feiner, Simon Julier, and Blair MacIntyre. Recent advances in augmented reality. *IEEE computer graphics and applications*, 21(6):34–47, 2001.
- Ronald T Azuma. A survey of augmented reality. *Presence: Teleoperators & Virtual Environments*, 6(4):355–385, 1997.
- Seok-Hyung Bae, Ravin Balakrishnan, and Karan Singh. Ilovesketch: as-natural-as-possible sketching system for creating 3d curve models. In *Proceedings of the 21st annual ACM symposium on User interface software and technology*, pages 151–160, 2008.
- Huidong Bai, Gun A Lee, Mukundan Ramakrishnan, and Mark Billinghurst. 3d gesture interaction for handheld augmented reality. In *SIGGRAPH Asia 2014 Mobile Graphics and Interactive Applications*, pages 1–6. 2014.

- Filippo Bergamasco, Andrea Albarelli, Emanuele Rodola, and Andrea Torsello. Rune-tag: A high accuracy fiducial marker with strong occlusion resilience. In *CVPR 2011*, pages 113–120. IEEE, 2011.
- Oriel Bergig, Nate Hagbi, Jihad El-Sana, and Mark Billinghurst. In-place 3d sketching for authoring and augmenting mechanical systems. In *2009 8th IEEE International Symposium on Mixed and Augmented Reality*, pages 87–94. IEEE, 2009.
- Peter Brandl, Michael Haller, Michael Hurnaus, Verena Lugmayr, Juergen Oberngruber, Claudia Oster, Christian Schafleitner, and Mark Billinghurst. An adaptable rear-projection screen using digital pens and hand gestures. In *17th International Conference on Artificial Reality and Telexistence (ICAT 2007)*, pages 49–54. IEEE, 2007.
- Klen Čopič Pucihar, Paul Coulton, and Jason Alexander. Evaluating dual-view perceptual issues in handheld augmented reality: device vs. user perspective rendering. In *Proceedings of the 15th ACM on International conference on multimodal interaction*, pages 381–388, 2013.
- Sergio Garrido-Jurado, Rafael Muñoz-Salinas, Francisco José Madrid-Cuevas, and Manuel Jesús Marín-Jiménez. Automatic generation and detection of highly reliable fiducial markers under occlusion. *Pattern Recognition*, 47(6):2280–2292, 2014.
- Ravindra S Goonetilleke, Errol R Hoffmann, and Ameersing Luximon. Effects of pen design on drawing and writing performance. *Applied ergonomics*, 40(2):292–301, 2009.
- Nate Hagbi, Oriel Bergig, Jihad El-Sana, and Mark Billinghurst. Shape recognition and pose estimation for mobile augmented reality. *IEEE transactions on visualization and computer graphics*, 17(10):1369–1379, 2010a.
- Nate Hagbi, Raphaël Grasset, Oriel Bergig, Mark Billinghurst, and Jihad El-Sana. In-place sketching for content authoring in augmented reality games. In *2010 IEEE Virtual Reality Conference (VR)*, pages 91–94. IEEE, 2010b.

- Marc Hassenzahl. The interplay of beauty, goodness, and usability in interactive products. *Human-Computer Interaction*, 19(4):319–349, 2004.
- Marc Hassenzahl, Michael Burmester, and Franz Koller. Attraktivität: Ein Fragebogen zur Messung wahrgenommener hedonischer und pragmatischer Qualität. In *Mensch & Computer 2003*, pages 187–196. Springer, 2003.
- Tobias Höllerer and Steve Feiner. Mobile augmented reality. *Teleinformatics: Location-based computing and services*, 21, 2004.
- Ke Huo and Karthik Ramani. Window-shaping: 3d design ideation by creating on, borrowing from, and looking at the physical world. In *Proceedings of the Eleventh International Conference on Tangible, Embedded, and Embodied Interaction*, pages 37–45, 2017.
- Takeo Igarashi, Satoshi Matsuoka, and Hidehiko Tanaka. Teddy: a sketching interface for 3d freeform design. In *ACM SIGGRAPH 2006 Courses*, pages 11–es. 2006.
- Bret Jackson and Daniel F Keefe. Lift-off: Using reference imagery and freehand sketching to create 3d models in vr. *IEEE transactions on visualization and computer graphics*, 22(4):1442–1451, 2016.
- Ernst Kruijff, J Edward Swan, and Steven Feiner. Perceptual issues in augmented reality revisited. In *2010 IEEE International Symposium on Mixed and Augmented Reality*, pages 3–12. IEEE, 2010.
- Tobias Langlotz, Stefan Mooslechner, Stefanie Zollmann, Claus Degendorfer, Gerhard Reitmayr, and Dieter Schmalstieg. Sketching up the world: in situ authoring for mobile augmented reality. *Personal and ubiquitous computing*, 16(6):623–630, 2012.
- Taehee Lee and Tobias Hollerer. Handy ar: Markerless inspection of augmented reality objects using fingertip tracking. In *2007 11th IEEE International Symposium on Wearable Computers*, pages 83–90. IEEE, 2007.
- James R Lewis. Psychometric evaluation of the post-study system usability questionnaire: The pssuq. In *Proceedings of the Human Factors and Ergonomics Society Annual*

- Meeting*, volume 36, pages 1259–1260. SAGE Publications Sage CA: Los Angeles, CA, 1992.
- Nianlong Li, Teng Han, Feng Tian, Jin Huang, Minghui Sun, Pourang Irani, and Jason Alexander. Get a grip: Evaluating grip gestures for vr input using a lightweight pen. In *Proceedings of the 2020 CHI Conference on Human Factors in Computing Systems*, pages 1–13, 2020.
- Bojan Milosevic, Flavio Bertini, Elisabetta Farella, and Serena Morigi. A smartpen for 3d interaction and sketch-based surface modeling. *The International Journal of Advanced Manufacturing Technology*, 84(5-8):1625–1645, 2016.
- Iris Seidinger and Jens Grubert. 3d character customization for non-professional users in handheld augmented reality. In *2016 IEEE International Symposium on Mixed and Augmented Reality (ISMAR-Adjunct)*, pages 129–134. IEEE, 2016.
- Didier Stricker, Alain Pagani, and Michael Zoellner. In-situ visualization for cultural heritage sites using novel augmented reality technologies. *Virtual Archaeology Review*, 1(2):37–41, 2010.
- Ivan E Sutherland. Sketchpad a man-machine graphical communication system. *Simulation*, 2(5):R-3, 1964.
- PC Thomas and WM David. Augmented reality: An application of heads-up display technology to manual manufacturing processes. In *Hawaii International Conference on System Sciences*, pages 659–669, 1992.
- DWF Van Krevelen and Ronald Poelman. A survey of augmented reality technologies, applications and limitations. *International journal of virtual reality*, 9(2):1–20, 2010.
- Philipp Wacker, Adrian Wagner, Simon Voelker, and Jan Borchers. Physical guides: An analysis of 3d sketching performance on physical objects in augmented reality. In *Proceedings of the 6th Symposium on Spatial User Interaction, SUI '18*, New York, NY, USA, October 2018. ACM. ISBN 978-1-4503-5708-1. doi: 10.1145/3267782.3267788. URL <https://doi.org/10.1145/3267782.3267788>.

- Philipp Wacker, Oliver Nowak, Simon Voelker, and Jan Borchers. Arpen: Mid-air object manipulation techniques for a bimanual ar system with pen & smartphone. In *Proceedings of the 2019 CHI Conference on Human Factors in Computing Systems, CHI '19*, pages 619:1–619:10, New York, NY, USA, May 2019. ACM. ISBN 978-1-4503-5970-2/19/05. doi: 10.1145/3290605.3300849. URL <https://doi.org/10.1145/3290605.3300849>.
- Daniel Wagner, Gerhard Reitmayr, Alessandro Mulloni, Tom Drummond, and Dieter Schmalstieg. Pose tracking from natural features on mobile phones. In *2008 7th IEEE/ACM International Symposium on Mixed and Augmented Reality*, pages 125–134. IEEE, 2008.
- Robert Wang, Sylvain Paris, and Jovan Popović. 6d hands: markerless hand-tracking for computer aided design. In *Proceedings of the 24th annual ACM symposium on User interface software and technology*, pages 549–558, 2011.
- Felix Wehnert. Pen-based drawing in augmented reality on mobile phones. Bachelor’s thesis, RWTH Aachen University, Aachen, April 2018.
- Gerold Wesche and Hans-Peter Seidel. Freedrawer: a free-form sketching system on the responsive workbench. In *Proceedings of the ACM symposium on Virtual reality software and technology*, pages 167–174, 2001.
- Eva Wiese, Johann Habakuk Israel, Achim Meyer, and Sara Bongartz. Investigating the learnability of immersive free-hand sketching. In *Proceedings of the Seventh Sketch-Based Interfaces and Modeling Symposium*, pages 135–142, 2010.
- Po-Chen Wu, Robert Wang, Kenrick Kin, Christopher Twigg, Shangchen Han, Ming-Hsuan Yang, and Shao-Yi Chien. Dodecapen: Accurate 6dof tracking of a passive stylus. In *Proceedings of the 30th Annual ACM Symposium on User Interface Software and Technology*, pages 365–374, 2017.
- Min Xin, Ehud Sharlin, and Mario Costa Sousa. Napkin sketch: handheld mixed reality 3d sketching. In *Proceedings of the 2008 ACM symposium on Virtual reality software and technology*, pages 223–226, 2008.

- Sang Ho Yoon, Ke Huo, and Karthik Ramani. Tmotion: Embedded 3d mobile input using magnetic sensing technique. In *Proceedings of the TEI'16: Tenth International Conference on Tangible, Embedded, and Embodied Interaction*, pages 21–29, 2016.
- Koray Yucel, Nevzat Orhan, Gizem Misirli, Gözde Bal, and Yasar Guneri Sahin. An improved interactive whiteboard system: A new design and an ergonomic stylus. In *2010 2nd International Conference on Education Technology and Computer*, volume 3, pages V3–148. IEEE, 2010.
- Ya-Ting Yue, Xiaolong Zhang, Yongliang Yang, Gang Ren, Yi-King Choi, and Wenping Wang. Wiredraw: 3d wire sculpturing guided with mixed reality. In *Proceedings of the 2017 CHI Conference on Human Factors in Computing Systems*, pages 3693–3704, 2017.

Index

ARPen, 9, 12–14
ARPen dimensions, 26–27, 36
ArUco, 11, 37
AttrakDiff 2, 54, 57–58, 92–93
Autodesk Fusion 360, 25

Bonferroni correction, 55, 58

comments, 60–62
cube, *see* marker cube
cube orientation, 35
cube positions, 31–34

- Back, 33
- BackFront, 34
- BackFrontSmall, 34
- BackTop, 34
- Front, 33
- Top, 33
- TopFront, 34

Cura, *see* Ultimaker Cura

DodecaPen, 3, 8, 12
dual-view problem, 2

fiducial markers, 12
FreeDrawer, 9
Friedman test, 55, 58
Fusion 360, *see* Autodesk Fusion 360
future work, 66

global ranking, 55

hand tracking, 13

ILoveSketch, 6

KiCad, 16

Lift-Off, 3, 8–9

- marker cube, 13
- MarkerPen, 3, 8, 12
- mask layer, 18

- Napkin Sketch, 6

- PCB layout, 16–18
- Post-Study System Usability Questionnaire, 54, 59, 90–91
- pySerial, 21

- questionnaire, 73–90
 - english, 82–90
 - german, 73–82

- ranking, *see* global ranking
- RN4871, 15–16, 67
- RUNE-Tag, 11
- RX, 20

- shank sizes, 11
- Sketchpad, 5
- SmartPen, 9
- software adaption, 48–49
- stencil, 18–19
- study, 51–63
- SymbiosisSketch, 8

- Teddy, 6
- tip calculation, 37–46
 - angles, 38
 - Back, 40–41
 - Front, 42
 - Top, 42–46
- tripod grip, 11
- TX, 20

- Ultimaker Cura, 27, 36

- Wilcoxon Signed-rank, 55, 58
- Window-Shaping, 7
- WireDraw, 12

